

**110' ROW – Principal 6 Lane
Divided Arterial
Regular Section**
(Not to Scale)

- ① SAWED LONGITUDINAL CONTRACTION, OR CONSTRUCTION JOINT

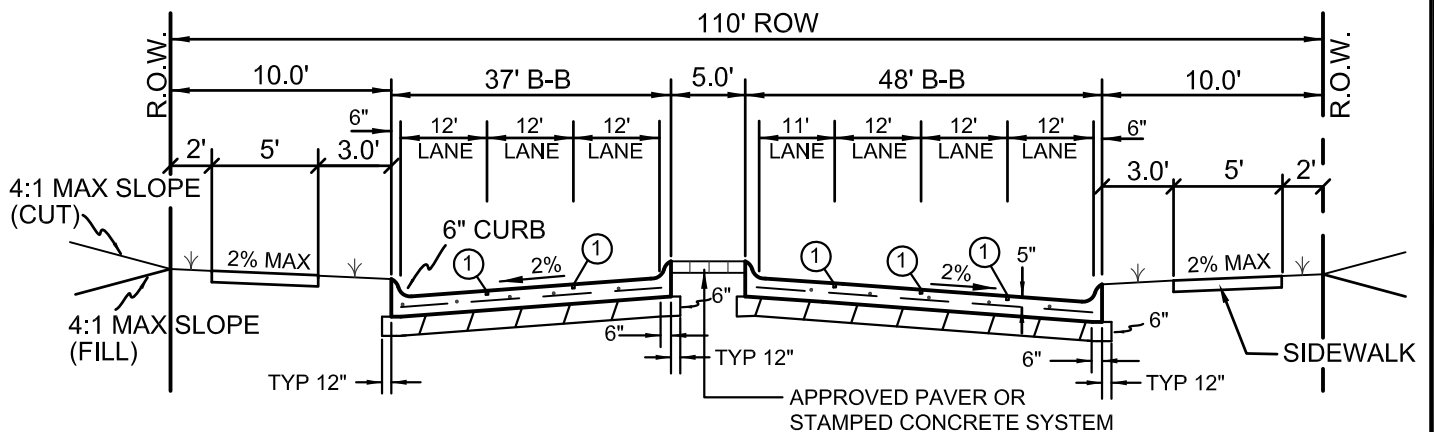

Left Turn Section
(Not to Scale)

NOTES:

1. Street pavement cement content to be no less than 6.0 sacks per cubic yard for machine placed and not less than 6.5 sacks per cubic yard for hand placed.
2. Sidewalk Cement content of not less than 5.5 sack per cubic yard.
3. No sand allowed under pavement or sidewalks.
4. Minimum lime content shall be 6% of dry weight of material (at least 27 lbs/SY) compact to 95% standard density.
5. Paving Section design shall be based off the 30 year projected traffic volumes and geotechnical analysis/report.

REINFORCED CONCRETE PAVEMENT

(P6D) PRINCIPAL ARTERIAL DIVIDED 6-LANE

CITY OF ROCKWALL



DATE
AUG. '15

DRAWING NO.
R-2010

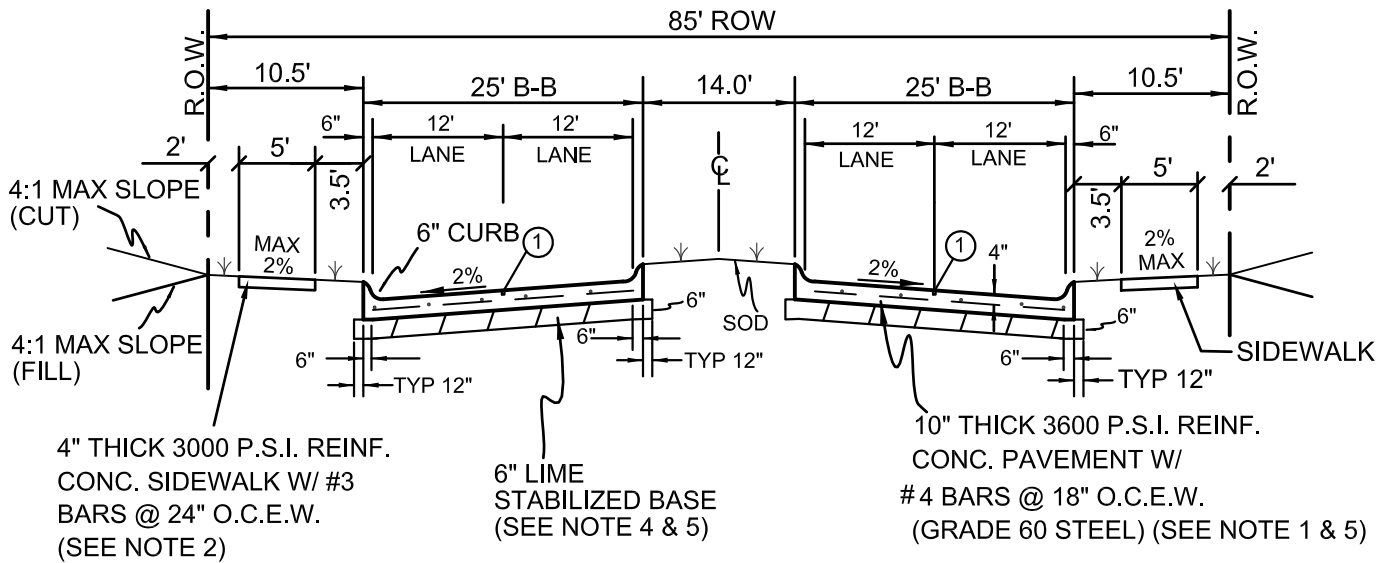

**85' ROW – Minor 4 Lane
Divided Arterial
Regular Section**
(Not to Scale)

① SAWED LONGITUDINAL CONTRACTION, OR CONSTRUCTION JOINT

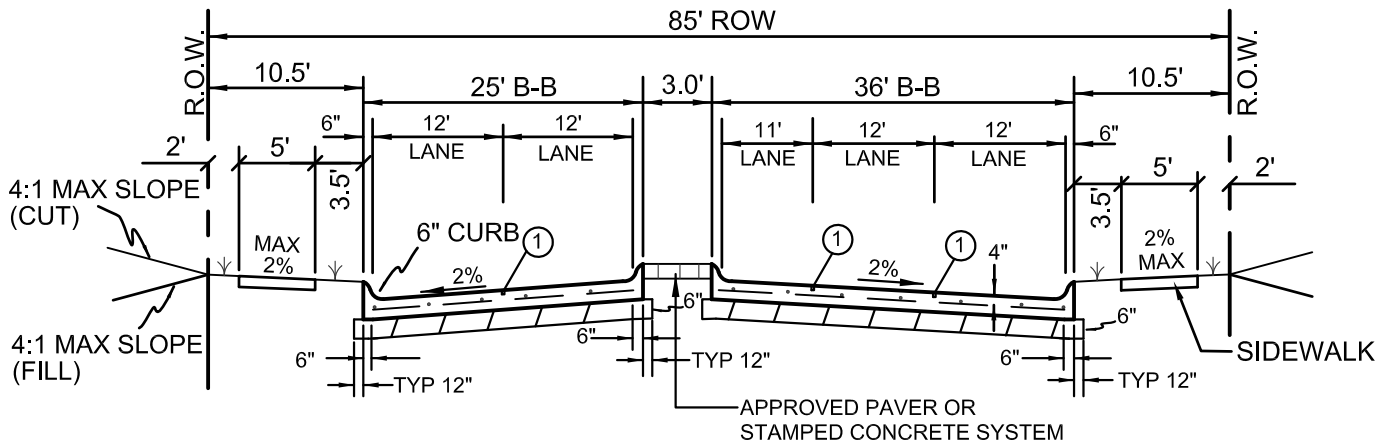

Left Turn Section
(Not to Scale)

NOTES:

1. Street pavement cement content to be no less than 6 sacks per cubic yard for machine placed and not less than 6.5 sacks per cubic yard for hand placed.
2. Sidewalk Cement content of not less than 5.5 sack per cubic yard.
3. No sand allowed under pavement or sidewalks.
4. Minimum lime content shall be 6% of dry weight of material (at least 27 lbs/SY) compacted to 95% standard density.
5. Paving Section design shall be based off the 30 year projected traffic volumes and geotechnical analysis/report.

REINFORCED CONCRETE PAVEMENT

(M4D) MINOR ARTERIAL DIVIDED 4-LANE

CITY OF ROCKWALL



DATE
AUG. '15

DRAWING NO.
R-2020

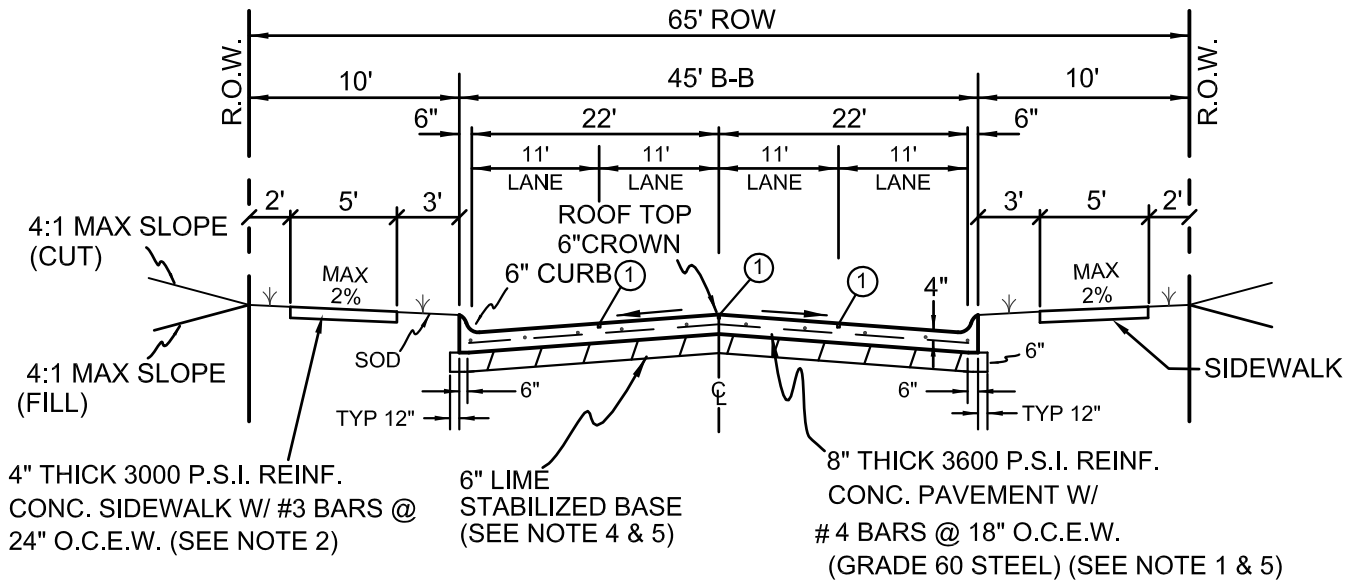

① SAWED LONGITUDINAL CONTRACTION, OR CONSTRUCTION JOINT

65' ROW – Major 4 Lane Undivided Collector
(Not to Scale)

NOTES:

1. Street pavement cement content to be no less than 6 sacks per cubic yard for machine placed and not less than 6.5 sacks per cubic yard for hand placed.
2. Sidewalk Cement content of not less than 5.5 sack per cubic yard.
3. No sand allowed under pavement or sidewalks.
4. Minimum lime content shall be 6% of dry weight of material (at least 27 lbs/SY) compacted to 95% standard density.
5. Paving Section design shall be based off 30 year projected traffic volumes and geotechnical analysis/report.

REINFORCED CONCRETE PAVEMENT

(M4U) MAJOR COLLECTOR UNDIVIDED 4-LANE

CITY OF ROCKWALL



DATE
AUG. '15

DRAWING NO.
R-2030

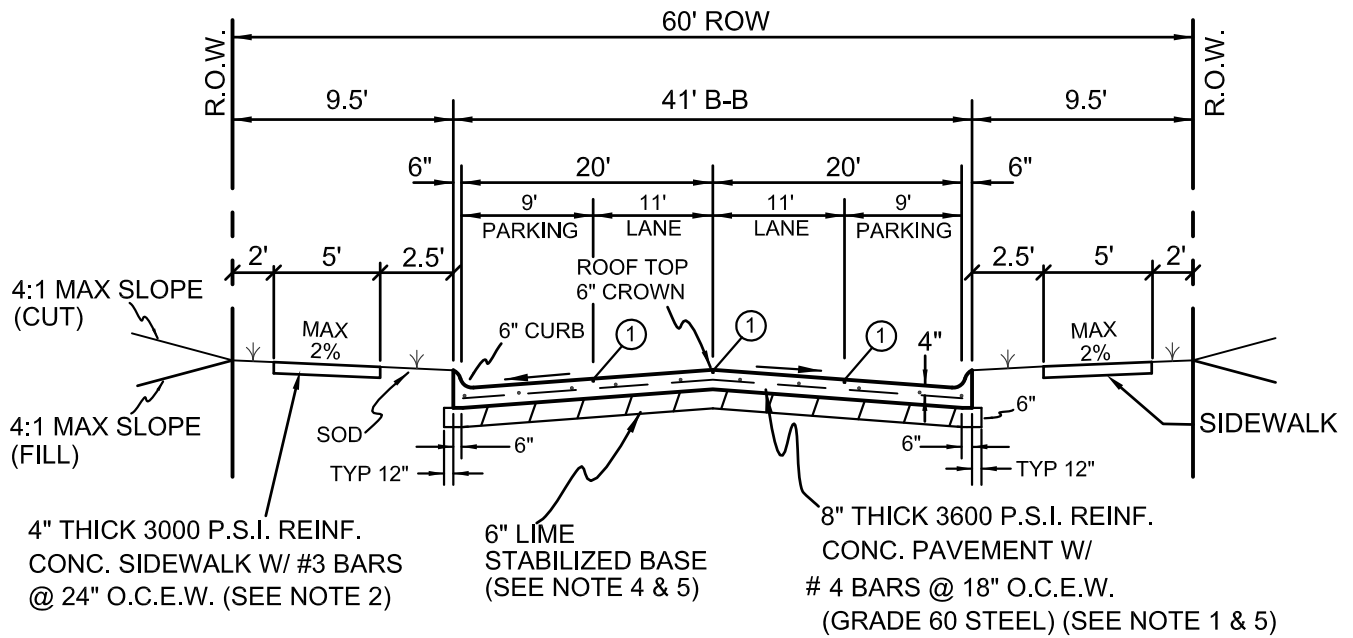

① SAWED LONGITUDINAL CONTRACTION, OR CONSTRUCTION JOINT

**60' ROW – Minor Collector
and or Local Commercial**
(Not to Scale)

NOTES:

1. Street pavement cement content to be no less than 6 sacks per cubic yard for machine placed and not less than 6.5 sacks per cubic yard for hand placed.
2. Sidewalk Cement content of not less than 5.5 sack per cubic yard.
3. No sand allowed under pavement or sidewalks.
4. Minimum lime content shall be 6% of dry weight of material (at least 27 lbs/SY) compacted to 95% standard density.
5. Paving Section design shall be based off the 30 year traffic volumes and geotechnical analysis/report.

REINFORCED CONCRETE PAVEMENT

CITY OF ROCKWALL

MINOR COLLECTOR/LOCAL COMMERCIAL



DATE
AUG. '15

DRAWING NO.
R-2031

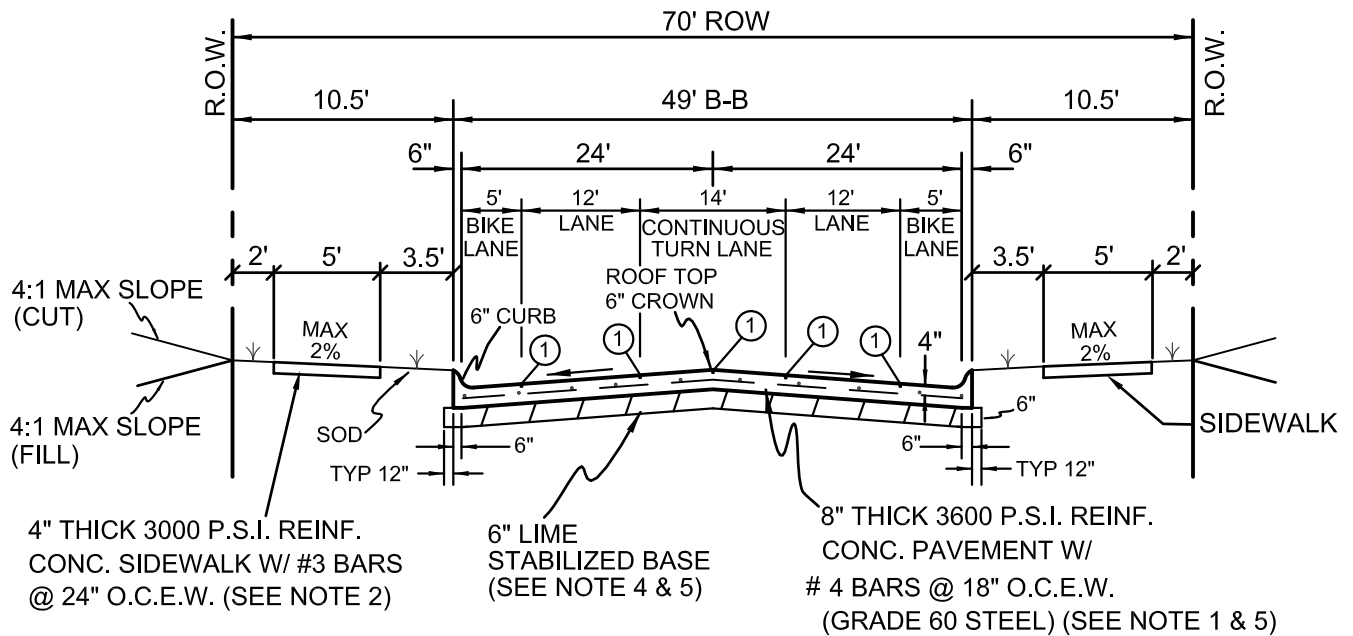

① SAWED LONGITUDINAL CONTRACTION, OR CONSTRUCTION JOINT

**70' ROW – Minor Collector
2 Lane with Continuous Left Turn Lane
(Not to Scale)**

NOTES:

1. Street pavement cement content to be no less than 6 sacks per cubic yard for machine placed and not less than 6.5 sacks per cubic yard for hand placed.
2. Sidewalk Cement content of not less than 5.5 sack per cubic yard.
3. No sand allowed under pavement or sidewalks.
4. Minimum lime content shall be 6% of dry weight of material (at least 27 lbs/SY) compacted to 95% standard density.
5. Paving Section design shall be based off the 30 year projected traffic volumes and geotechnical analysis/report.

REINFORCED CONCRETE PAVEMENT

CITY OF ROCKWALL

(M3U) MINOR COLLECTOR – 2 LANE
WITH CONTINUOUS LEFT TURN LANE



DATE
AUG. '15

DRAWING NO.
R-2032

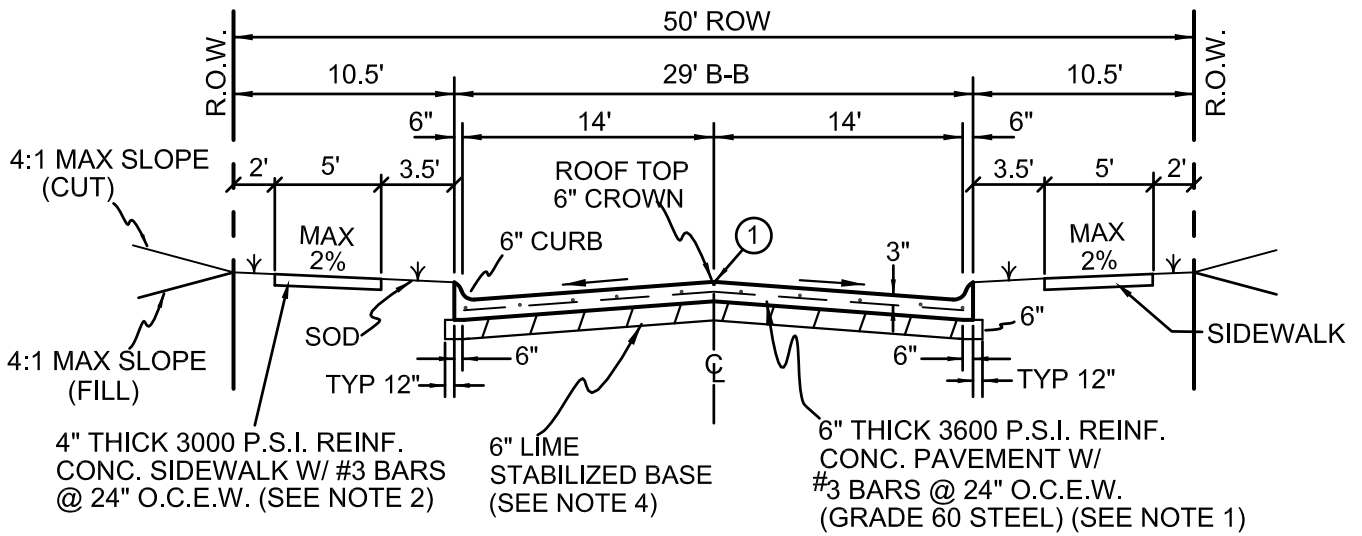

① SAWED LONGITUDINAL CONTRACTION, OR CONSTRUCTION JOINT

50' R.O.W. Residential Street
(Not to Scale)

NOTES:

1. Street pavement cement content to be no less than 6 sacks per cubic yard for machine placed and not less than 6.5 sacks per cubic yard for hand placed.
2. Sidewalk Cement content of not less than 5.5 sack per cubic yard.
3. No sand allowed under pavement or sidewalks.
4. Minimum lime content shall be 6% of dry weight of material (at least 27 lbs/SY) compacted to 95% standard density.

REINFORCED CONCRETE PAVEMENT

CITY OF ROCKWALL

LOCAL RESIDENTIAL STREET



DATE
AUG. '19

DRAWING NO.
R-2033

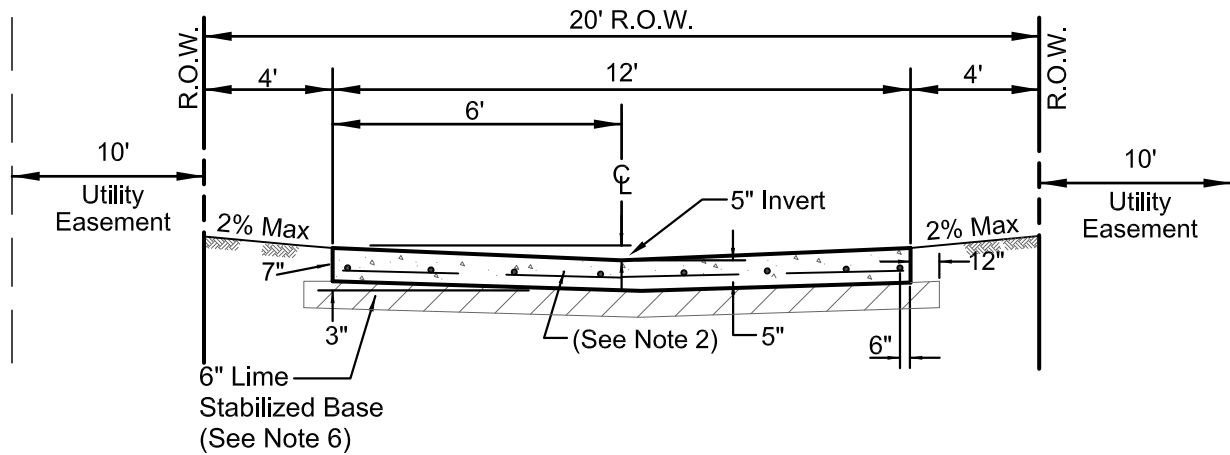

ALLEY SECTION WITHOUT CURB
(Not to Scale)

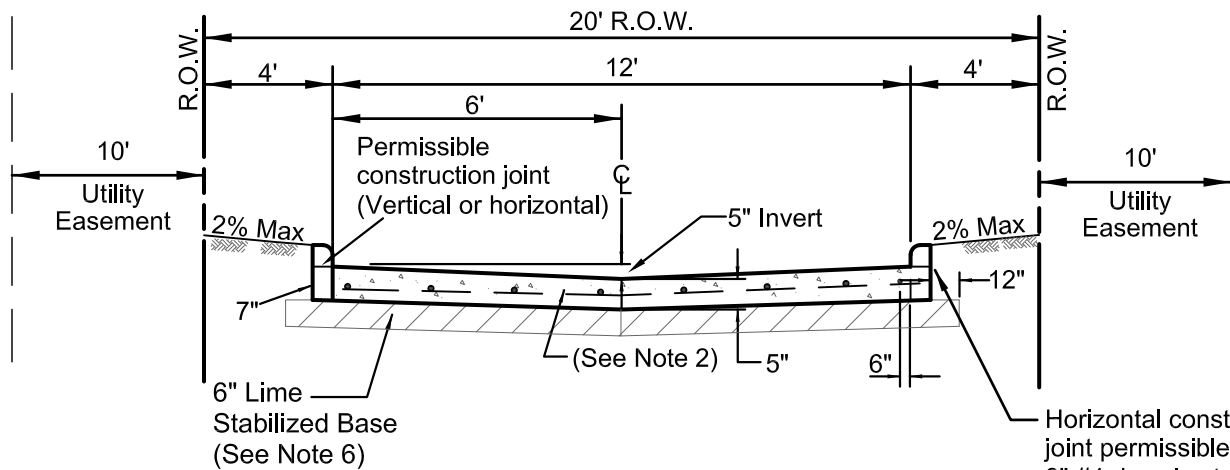

ALLEY SECTION WITH CURB
(Not to Scale)

Horizontal construction joint permissible with 8" #4 dowels at 12" C-C and longitudinal #4 bar in curb.

NOTES:

1. Provide sawed transverse contraction joints not more than 20' C-C.
2. Reinforced with no. 3 bars at 24" C-C both ways.
3. Expansion joints to be placed at all intersections and not to exceed 600' between joints.
4. Concrete shall be 7"-5"-7" Thick 3,600 P.S.I., Alley cement content shall be min. 6.0 sack for machine placed and 6.5 sack mix for hand placed.
5. No sand allowed under pavement.
6. Minimum lime content shall be 6% of dry weight of material (at least 27 lbs/SY) compacted to 95% standard density.

REINFORCED CONCRETE PAVEMENT	CITY OF ROCKWALL		
ALLEYS		DATE AUG '19	DRAWING NO. R-2040

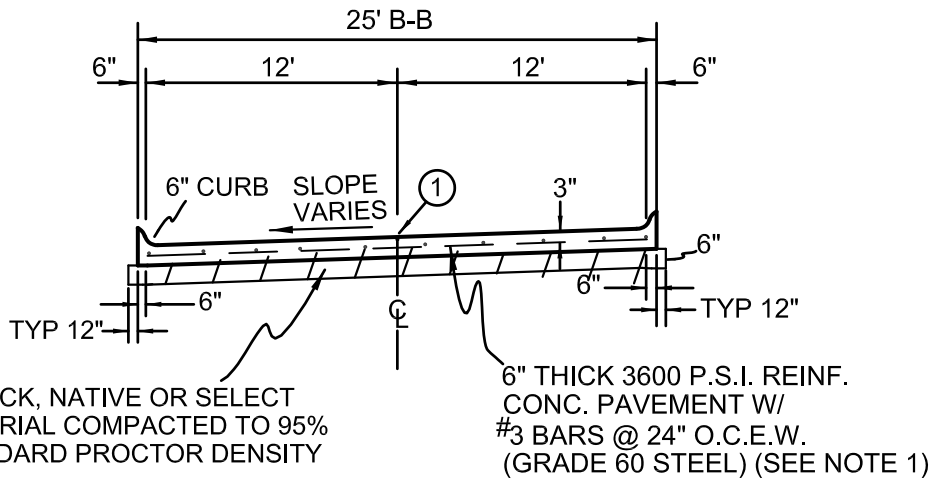

24' Wide Fire Lane with Curbs
(Not to Scale)

① SAWED LONGITUDINAL CONTRACTION OR CONSTRUCTION JOINT

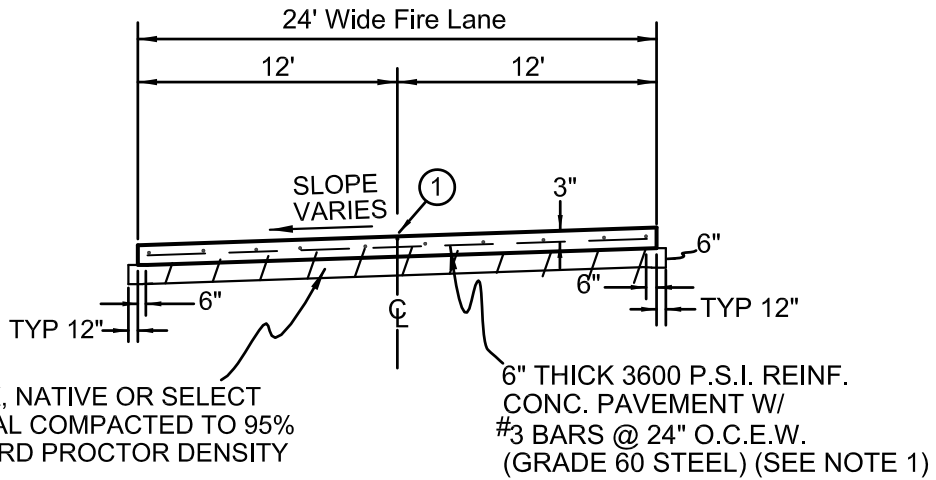

24' Wide Fire Lane
(Not to Scale)

NOTES:

1. Street pavement cement content to be no less than 6 sacks per cubic yard for machine placed and not less than 6.5 sacks per cubic yard for hand placed.
2. Sidewalk Cement content of not less than 5.5 sack per cubic yard.
3. No sand allowed under pavement or sidewalks.

REINFORCED CONCRETE PAVEMENT	CITY OF ROCKWALL		
FIRE LANE		DATE AUG. '19	DRAWING NO. R-2041

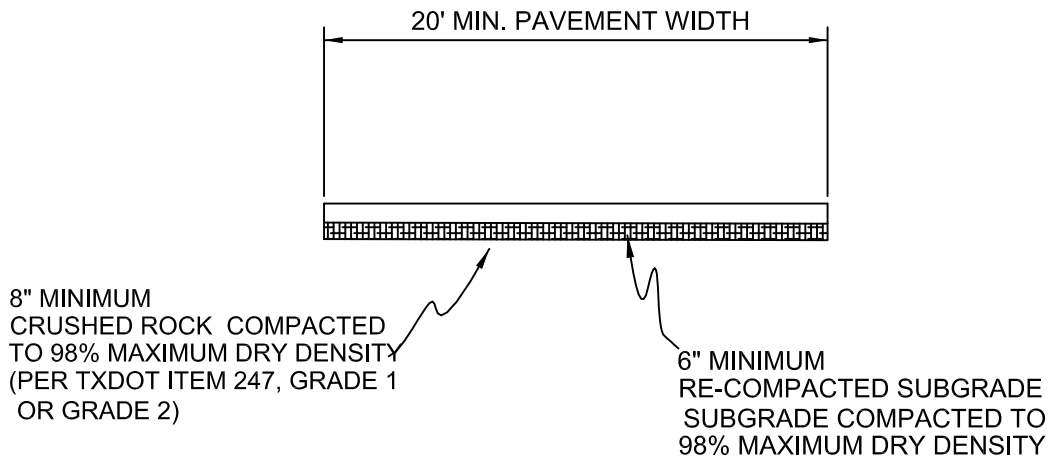

NOTES:

1. Every building constructed shall be accessible to emergency apparatus by way of temporary all weather driving surfaces.
2. A temporary all weather driving surface shall extend to within 150' of all exterior portions of buildings.
3. Temporary all weather driving surfaces shall be constructed as shown on construction plans.
4. Temporary all weather driving surfaces shall be capable of supporting a gross vehicle weight of 85,000 lbs. If subgrade conditions change or are very unstable, an additional geotechnical and/or engineering design may require a greater cross section.

TEMPORARY ALL WEATHER DRIVE	CITY OF ROCKWALL		
SURFACE DETAIL		DATE OCT. '15	DRAWING NO. R-2042

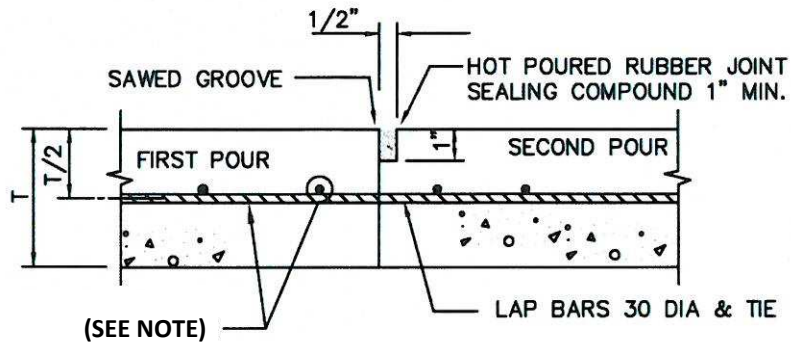

CONSTRUCTION JOINT

N.T.S.

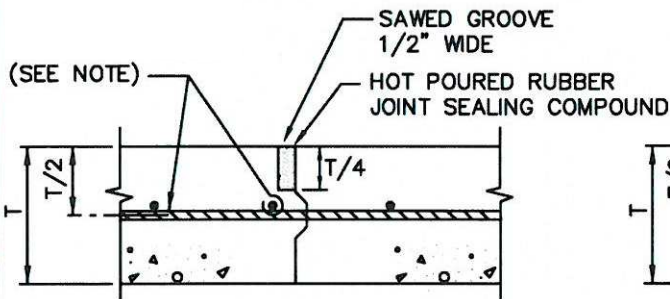

KEYWAY JOINT

(FOR PAVEMENT THICKNESS > 6")
N.T.S.

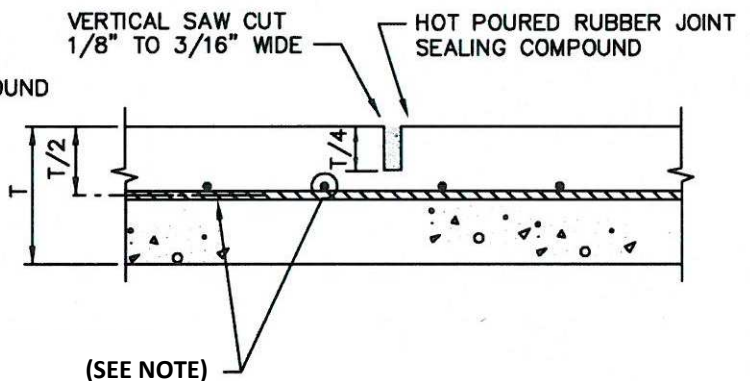

SAWED CONTRACTION JOINT

N.T.S.

NOTE:
REINFORCING SHALL BE - #3 BARS AT 24" FOR 6"
THICK PAVEMENT AND LESS. #4 BARS AT 18"
FOR 8" THICK PAVEMENT AND GREATER.

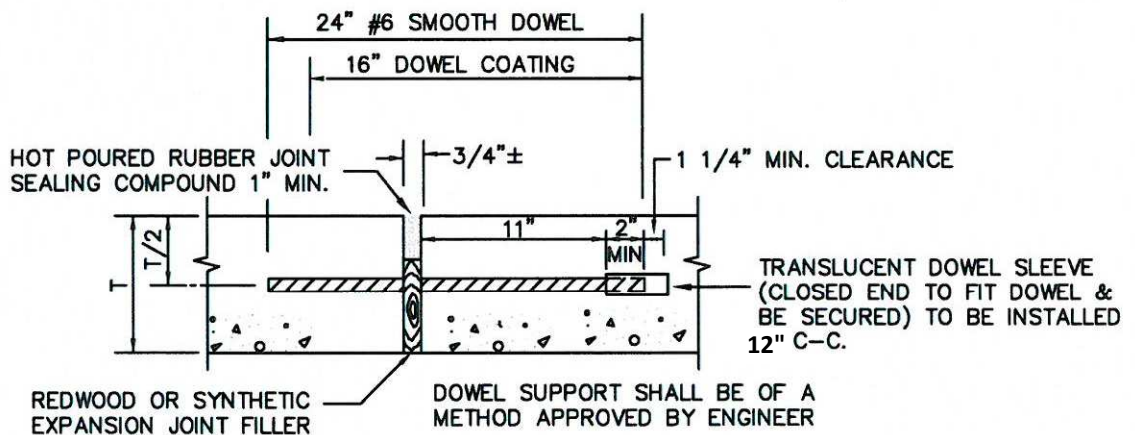

EXPANSION JOINT

(SPACED 600 FT. MAXIMUM; LOCATE AT
STRUCTURES AND AT INTERSECTION P.C.'S & P.T.'S)
N.T.S.

REINFORCED CONCRETE PAVEMENT

CITY OF ROCKWALL

STANDARD SPECIFICATION REFERENCE

303.5.4.

JOINTS



DATE

Mar. 2018

STANDARD DRAWING NO.

R-2050

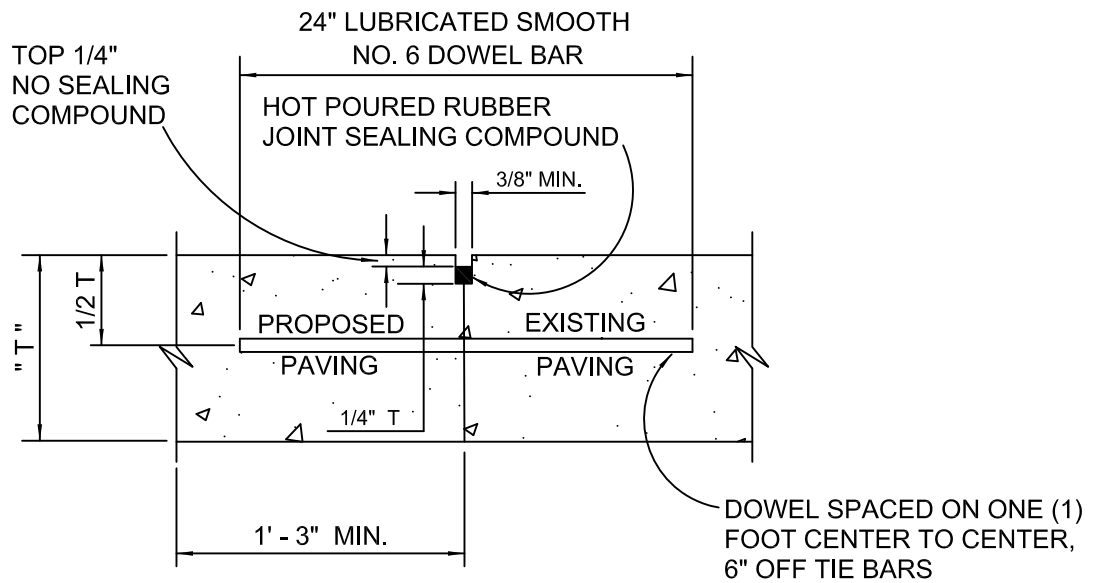

NOTES: T = PAVEMENT

1. LONGITUDINAL BUTT CONSTRUCTION MAY BE UTILIZED IN PLACE OF LONGITUDINAL HINGED (KEYWAY) JOINT AT CONTRACTORS OPTION.
2. DOWEL BARS SHALL BE DRILLED INTO PAVEMENT HORIZONTALLY BY USE OF A MECHANICAL RIG.
3. DRILLING BY HAND IS NOT ACCEPTABLE, PUSHING DOWEL BARS INTO GREEN CONCRETE NOT ACCEPTABLE.

LONGITUDINAL BUTT JOINT
NOT TO SCALE

REINFORCED CONCRETE PAVEMENT

CITY OF ROCKWALL

LONGITUDINAL BUTT JOINT



DATE
OCT. '17

DRAWING NO.
R-2051

EXPANSION JOINT FILLER

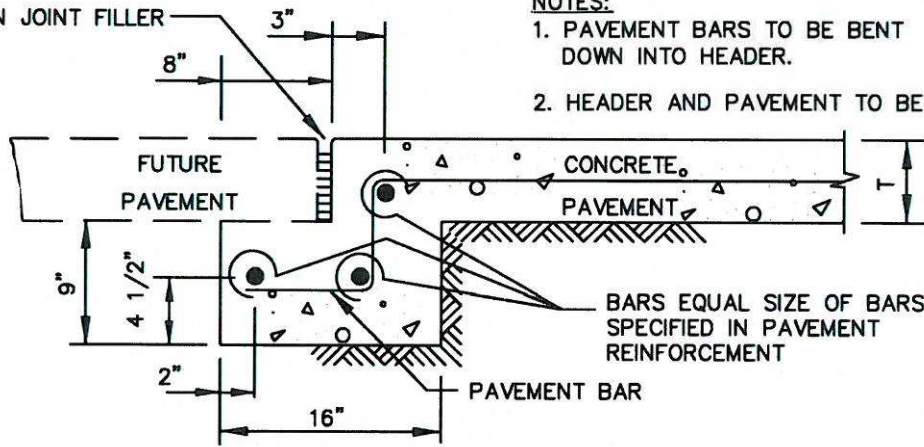

NOTES:

1. PAVEMENT BARS TO BE BENT DOWN INTO HEADER.
2. HEADER AND PAVEMENT TO BE MONOLITHIC.

BARS EQUAL SIZE OF BARS SPECIFIED IN PAVEMENT REINFORCEMENT

PAVEMENT BAR

STREET HEADER FOR FUTURE PAVEMENT

N.T.S.

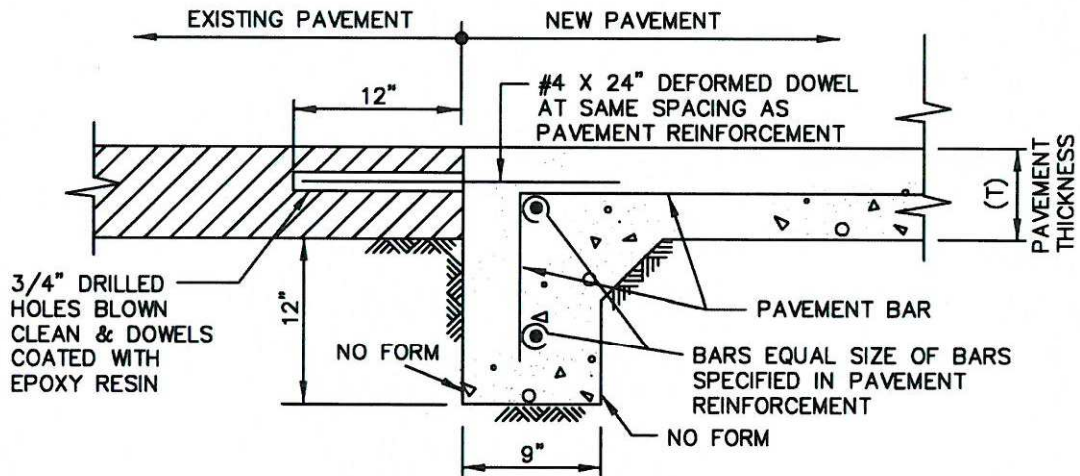

STREET HEADER AT EXISTING PAVEMENT

N.T.S.

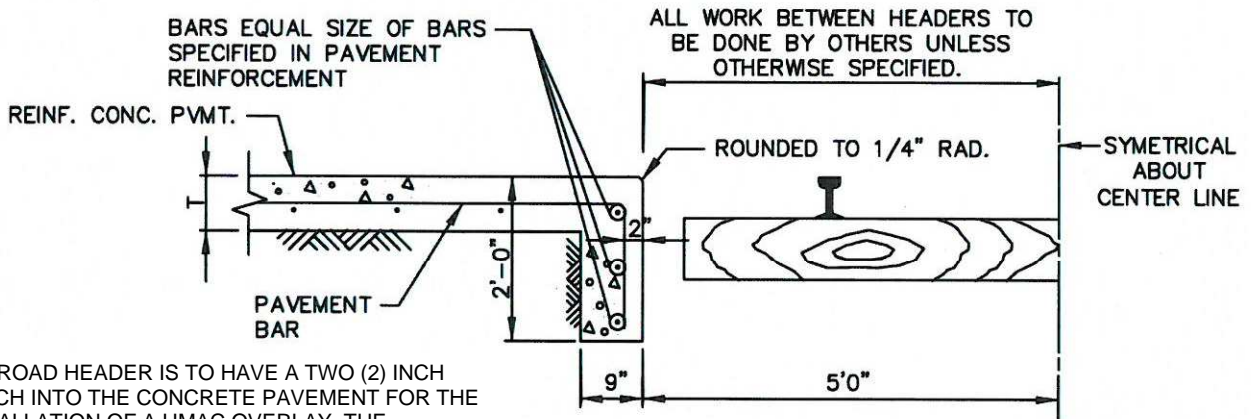

RAILROAD HEADER IS TO HAVE A TWO (2) INCH NOTCH INTO THE CONCRETE PAVEMENT FOR THE INSTALLATION OF A HMA OVERLAY. THE CONCRETE UNDER THE HMA IS TO BE THE FULL STREET THICKNESS. THE NOTCH SHOULD START AT THE END OF THE PAVEMENT AND GO TWENTY (20) FEET UP THE ROAD AWAY FROM THE CROSSING.

STREET HEADER AT RAILROAD

N.T.S.

REINFORCED CONCRETE PAVEMENT

CITY OF ROCKWALL

STANDARD SPECIFICATION REFERENCE

305.4

STREET HEADERS



DATE
Mar. 2018

STANDARD DRAWING NO.
R-2070

- EJ - Expansion Joint (See 2170MA for more details)
- CJ - Construction Joint
- Required limits of construction with street installation
- PROWAG = Public Rights-of-Way Accessibility Guidelines
- W -

The following is a typical detail for a directional curb ramp on a standard residential street and does not fit all scenarios in the City of Rockwall. It shall be the responsibility of the design consultant and contractor to ensure that all ramps constructed meet current ADA requirements.

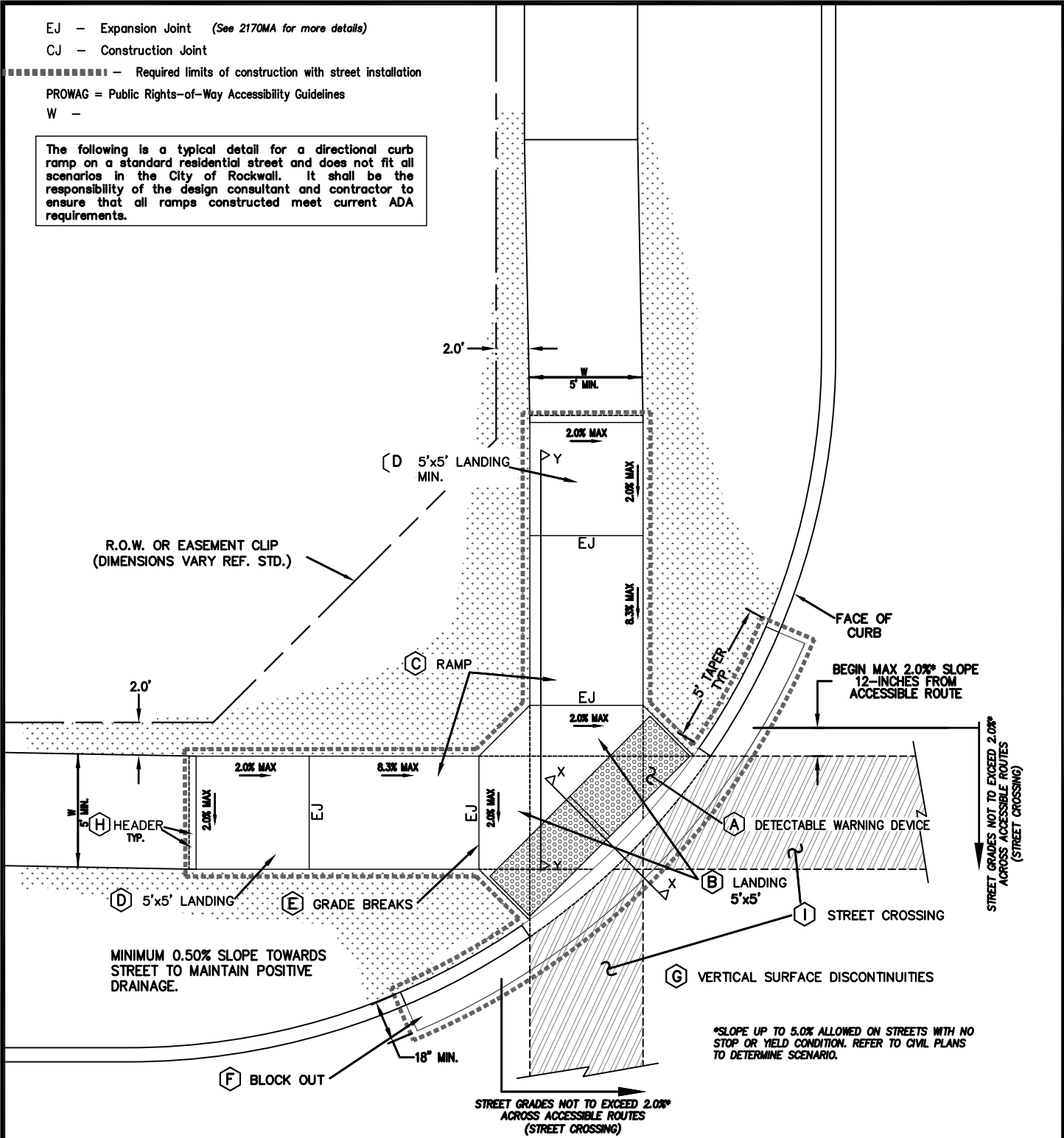

NOTES: All newly constructed sidewalks, curb ramps and crosswalks installed within City of Rockwall public rights-of-way shall be considered a pedestrian access route and shall conform to the most current "Draft" Guidelines for Public Rights-of-Way created by the United States Access Board.

1. SEE DETAIL R-2125B FOR RAMP FEATURE DESCRIPTIONS
2. SEE DETAIL R-2125C FOR SECTIONS X-X AND Y-Y
3. SEE DETAIL R-2125D FOR ADDITIONAL NOTES

DIRECTIONAL CURB RAMP	CITY OF ROCKWALL		
		DATE	DRAWING NO.
		MAR. '17	R-2125A

A

Detectable Warning Devices (DWD) shall be pre-manufactured cast-in-place truncated dome plates installed to the manufacturer's specifications, and shall meet all ADA requirements. No Brick Pavers allowed. Color to be approved by the City. DWD shall be 24 inches in length for the full width of the street connection starting at the back of curb. A maximum 2-inch border shall be allowed on the sides of the DWD for proper installation.

B

Also known as "Clear Space" per ADA PROWAG, the City requires a minimum landing space of 5-foot by 5-foot at the bottom of every ramp. This landing space shall have a cross slope in both directions that does not exceed 2.0% and shall be wholly outside the parallel vehicular travel path.

C

The ramp component of the directional curb ramp shall have a continuous longitudinal slope more than 5% and less than 8.3%. The ramp shall also have a cross slope of no more than 2.0%. Length of ramp can vary, but shall not exceed 15 feet to achieve desired elevation change.

D

Also known as "Turning Space" per ADA PROWAG, a minimum landing space of 5-foot by 5-foot shall be at the top of every ramp. This landing (turning) space shall have a cross slope in both directions that does not exceed 2.0%. Landing must match width of sidewalk and length shall be the same distance ("Squared" Landing).

E

All curb ramps shall have grade breaks at the top and bottom that are perpendicular to the direction of the ramp run. Where the ends of the bottom grade break are less than or equal to 5 feet, the DWD shall be placed within the ramp at the bottom grade break. Where either end of the bottom grade break is greater than 5 feet, the DWD shall be placed behind the back of the curb.

F

Paving contractor shall leave block out with a keyway joint installed, minimum of 18 inches measured from back of curb. Block out shall be poured monolithically with Curb Ramp. Concrete shall tie to street paving with a keyway joint per NCTCOG detail 2050. No curb shall be constructed where a DWD is provided. The curb on either side shall have a typical 5 foot taper to transition from the standard 6-inch curb height to be flush with ramp.

G

All work associated with accessible routes shall be installed flush with all features to minimize vertical surface discontinuities. Each segment along accessible route shall be flush with no more (zero tolerance) than a ¼-inch grade separation (elevation difference), or ½-inch grade separation if beveled (bevel slope shall not be steeper than 50%).

H

A sidewalk header shall be constructed at ends of all work performed.

I

Street crossings shall adhere to same guidelines as other accessible routes within public right-of-way, and shall be for the full width of the in-line accessible route. Cross slope shall not exceed 2%*. New street construction shall incorporate all ADA design requirements. It shall be the responsibility of the Design Professional and Contractor to ensure all street crossings meet the requirements of PROWAG. Street alterations on existing streets to bring to compliance shall be at the City Engineer's discretion.

J

All curbs constructed as part of an ADA Ramp shall match City curb standards.

* See PROWAG special design considerations when street crossing has no stop or yield condition.

DIRECTIONAL CURB RAMP

CITY OF ROCKWALL



DATE MAR. '17 DRAWING NO. R-2125B

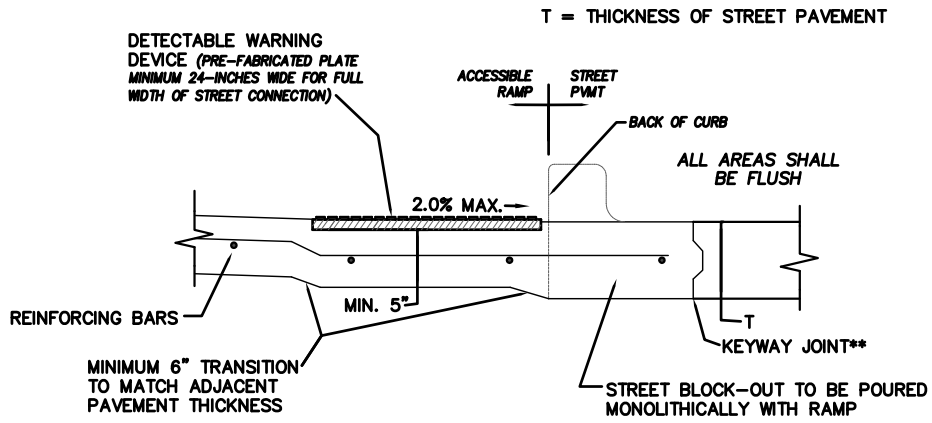

SECTION X-X
N.T.S.

**KEYWAY JOINT FOR NEW CONSTRUCTION. STREET CONNECTION SHALL BE LONGITUDINAL BUTT JOINT FOR CONNECTIONS TO EXISTING ROADWAYS.

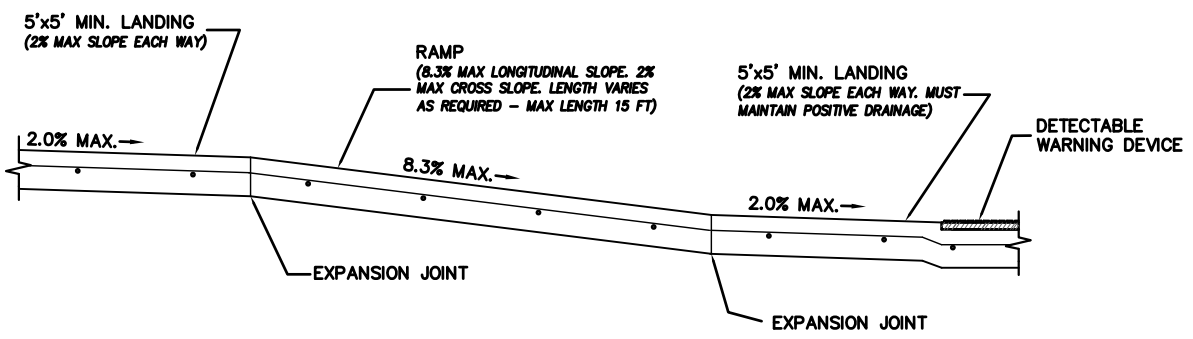

SECTION Y-Y
N.T.S.

NOTE: ALL SIDEWALK CURB RAMPS WILL BE 3,600 PSI (6.5 SACK/CY) CONCRETE.

DIRECTIONAL CURB RAMP	CITY OF ROCKWALL		
		DATE MAR. '17	DRAWING NO. R-2125C

PEDESTRIAN ACCESSIBILITY (WITHIN PUBLIC R.O.W.)

All newly constructed sidewalks, curb ramps and crosswalks installed within City of Rockwall public rights-of-way shall be considered a pedestrian access route and shall conform to the most current Guidelines for Public Rights-of-Way created by the United States Access Board.

CURB RAMPS

1. All slopes shown are MAXIMUM ALLOWABLE. Lesser slopes that will still drain properly should be used. Adjust curb ramp length or grade of approach sidewalks as directed.
2. Landings shall be 5'x 5' minimum with a maximum 2% slope in the transverse and longitudinal directions..
3. Clear space at the bottom of curb ramps shall be a minimum of 5'x 5' wholly contained within the crosswalk and wholly outside the parallel vehicular travel path.
4. Maximum allowable cross slope on sidewalk and curb ramp surfaces is 2%.
5. Additional information on curb ramp location, design, light reflective value and texture may be found in the most current edition of the Texas Accessibility Standards (TAS) and 16 TAC 68.102. Federal guidelines shall supersede any conflicts.
6. Crosswalk dimensions, crosswalk markings and stop bar locations shall be as shown elsewhere in the plans. At intersections where crosswalk markings are not required, curb ramps and accessible routes shall align with theoretical crosswalks unless otherwise directed.
7. Handrails are not required on curb ramps.
8. Provide a flush transition where the curb ramps connect to the street.
9. Accessible routes are considered "ramps" when longitudinal slopes are between 5% and 8.3% (maximum allowable). Sidewalks under 5% longitudinal slope are deemed accessible routes and must follow all applicable guidelines.

DETECTABLE WARNING DEVICE

10. Curb ramps must contain a detectable warning surface that consists of raised truncated domes complying with Section 705 of the TAS. The surface must contrast visually with adjoining surfaces. Furnish and install an approved cast-in-place dark red detectable warning surface material adjacent to uncolored concrete, unless specified elsewhere in the plans.
11. Detectable Warning Materials shall be truncated dome plates in the color approved by the City. Install products in accordance with manufacturer's specifications.
12. Detectable warning surfaces must be slip resistant and not allow water to accumulate.
13. Detectable warning surfaces shall be a minimum of 24" in depth in the direction of pedestrian travel, and extend the full width of the curb ramp or landing where the pedestrian access route enters the street.
14. Detectable warning surfaces shall be located so that the edge nearest the curb line is at the back of curb. When placed on the ramp, align the rows of domes to be perpendicular to the grade break between the ramp run and the street. Where detectable warning surfaces are provided on a surface with a slope that is less than 5 percent, dome orientation is less critical. Detectable warning surfaces may be curved along the corner radius.

SIDEWALKS

15. Provide clear ground space at operable parts, including pedestrian push buttons. Operable parts shall be placed within one or more reach ranges specified in TAS 308.
16. Place traffic signal or illumination poles, ground boxes, controller boxes, signs, drainage facilities and other items so as not to obstruct the pedestrian access route or clear ground space.
17. Street grades and cross slopes shall be as shown elsewhere in the plans.
18. Changes in level greater than 1/4 inch are not permitted (1/2 inch with bevel).
19. The least possible grade should be used to maximize accessibility. The running slope of sidewalks and crosswalks within the public right of way may follow the grade of the parallel roadway. Where a continuous grade greater than 5% must be provided, handrails may be desirable to improve accessibility. Handrails may also be needed to protect pedestrians from potentially hazardous conditions. If provided, handrails shall comply with TAS 505.
20. Handrail extensions shall not protrude into the usable landing area or into intersecting pedestrian routes.

DIRECTIONAL CURB RAMP

CITY OF ROCKWALL



DATE	DRAWING NO.
MAR. '17	R-2125D

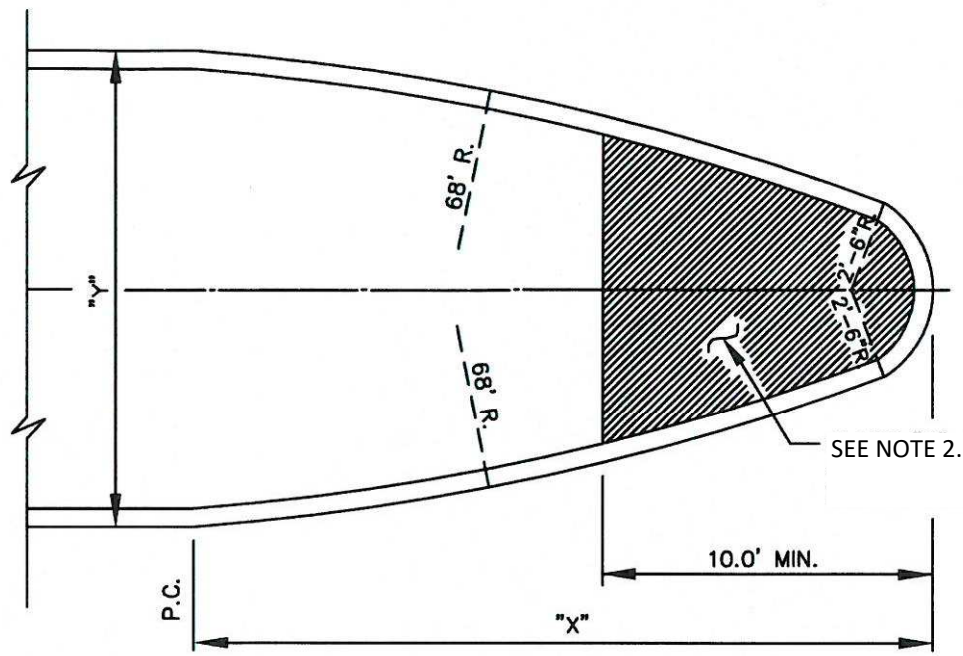

DIMENSIONS OF MEDIAN NOSE

Y = 15'	X = 27.6'
Y = 16'	X = 28.8'
Y = 17'	X = 29.9'
Y = 18'	X = 30.9'

CONCRETE NOSE FOR MEDIAN ISLAND

N.T.S.

NOTES

1. LEFT TURN LANE SHALL HAVE A MOWER ACCESS RAMP.
2. MEDIAN PAVING TO BE CONSTRUCTED OF INEGRAL STAMPED & STAINED REINFORCED CONCRETE, COLOR AND PATTERN TO BE APPROVED BY THE CITY. CONCRETE TO BE MINIMUM SIX (6") INCH 3600PSI (6.5 SACK/CY) WITH #4 BARS ON 18" CENTERS.
3. STREET LIGHT POLE BASES IN MEDIAN ARE TO HAVE THIRTY-SIX (36") INCH BY THIRTY-SIX (36") INCH, FOUR (4") INCH THICK, 3000PSI REINFORCED CONCRETE MOW STRIP.

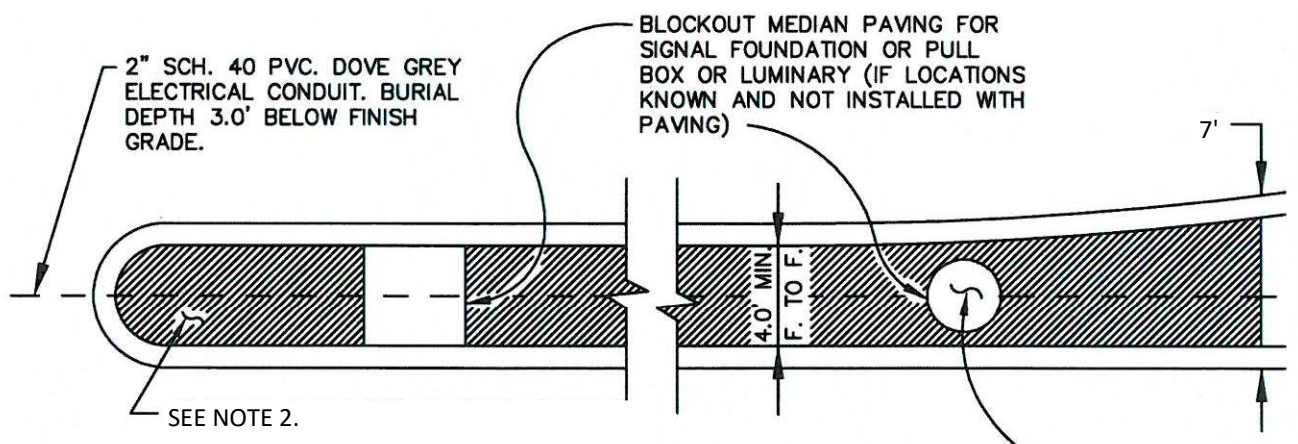

LEFT TURN LANE MEDIAN PAVEMENT

N.T.S.

<p>MEDIAN ISLAND PAVEMENT NOSE & LEFT TURN LANE</p>	<p>CITY OF ROCKWALL</p> 	<p>STANDARD SPECIFICATION REFERENCE 305.3</p>
		<p>DATE AUG. '19</p>

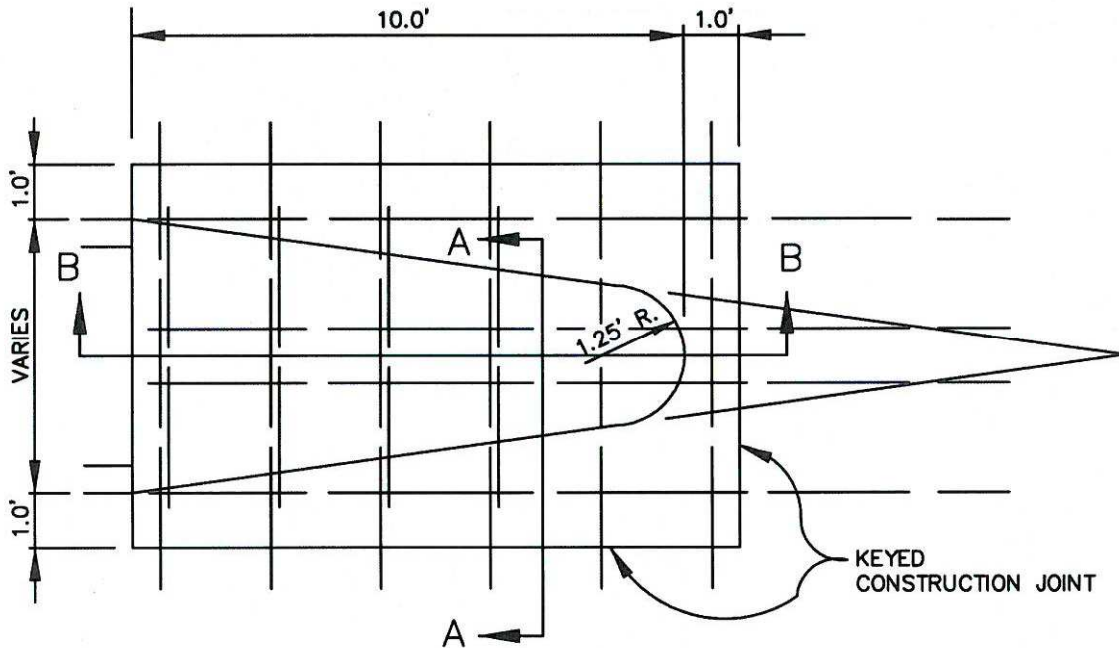

MONOLITHIC CONCRETE MEDIAN NOSE

N.T.S.

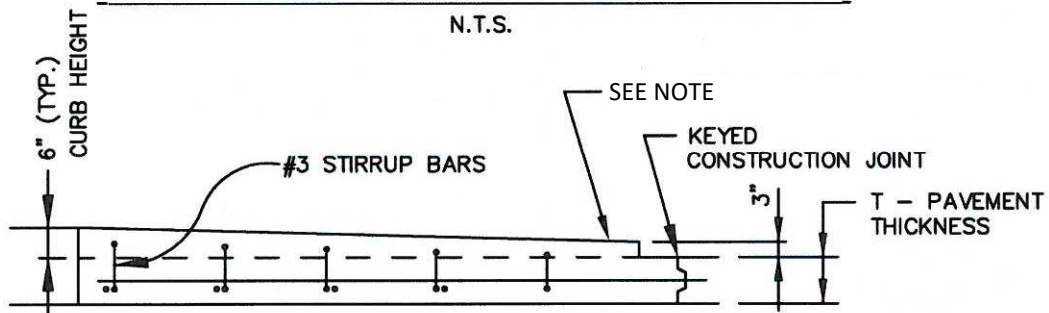

SECTION B-B

N.T.S.

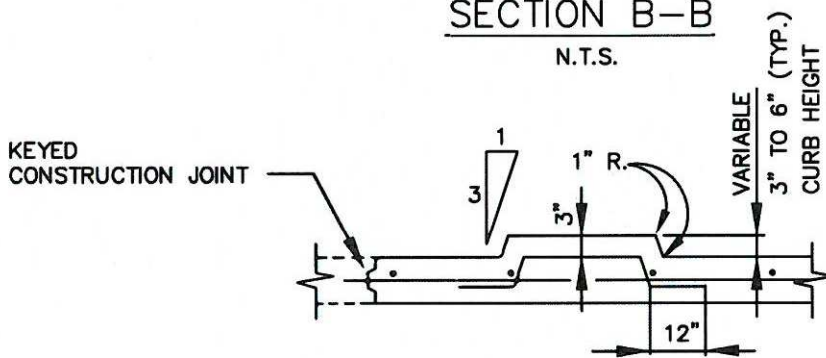

SECTION A-A

N.T.S.

- NOTE:
1. MEDIAN NOSE PAVEMENT STRENGTH SHALL MATCH THAT OF STREET PAVING.
 2. MONOLITHIC NOSE REQUIRED WHEN LESS THAN 6.0' FACE TO FACE.
 3. REINFORCEMENT BARS SHALL MATCH THOSE IN PAVEMENT.

MEDIAN ISLAND PAVEMENT
MONOLITHIC CONCRETE NOSE

CITY OF ROCKWALL



STANDARD SPECIFICATION REFERENCE
305.3

DATE: AUG. '19
STANDARD DRAWING NO.: R-2140

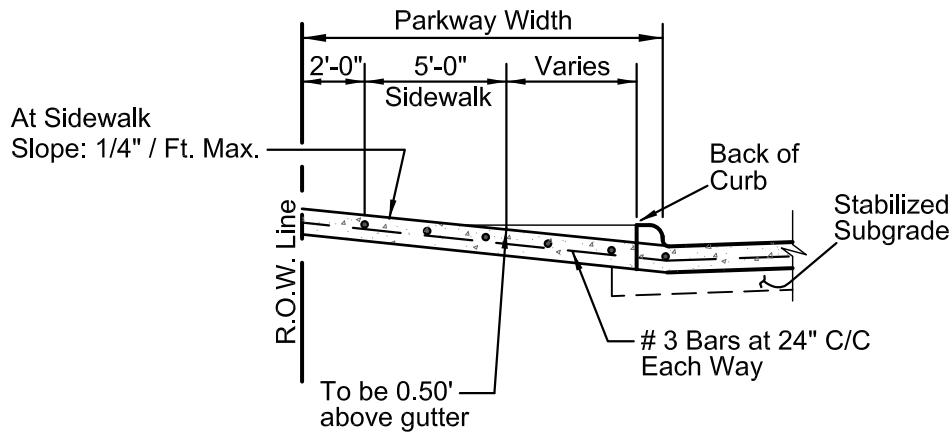

SECTION A-A

NOTE:

Sidewalk section thru driveway
to be poured same thickness as
driveway - 6" Thick 3,600 P.S.I.
Reinf. Conc. Pvmt. w/ #3 Bars
@ 24" O.C.E.W. (Grade 60 Steel)

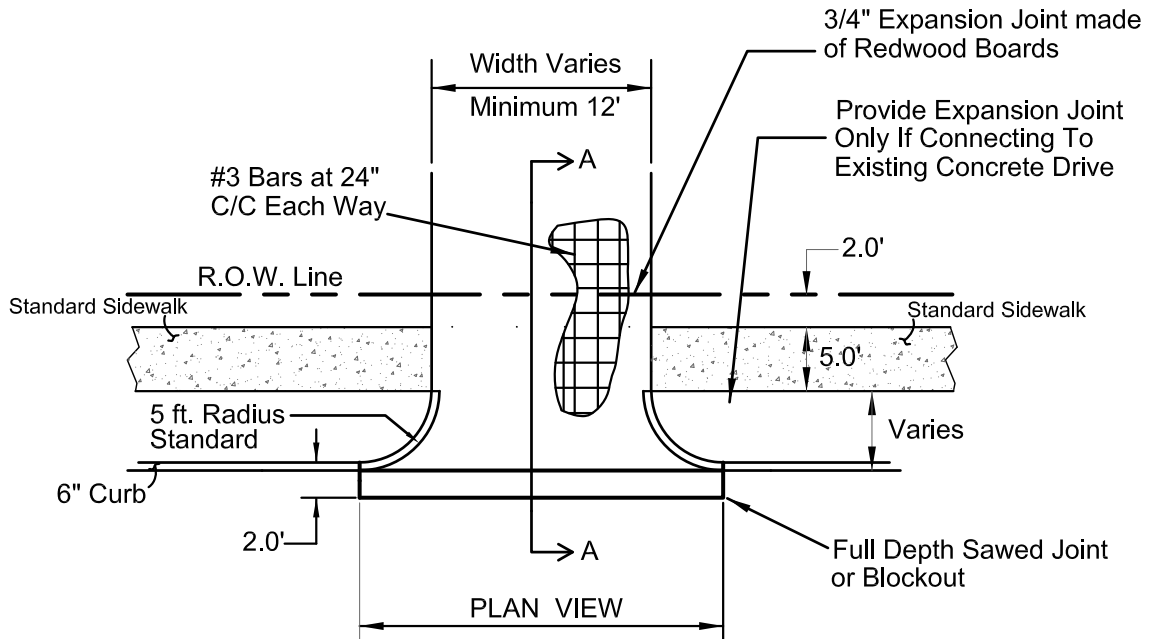

DRIVEWAY DETAILS
(Not to Scale)

DRIVEWAY DETAIL	CITY OF ROCKWALL		
RESIDENTIAL DRIVEWAY		DATE AUG '19	DRAWING NO. R-2150

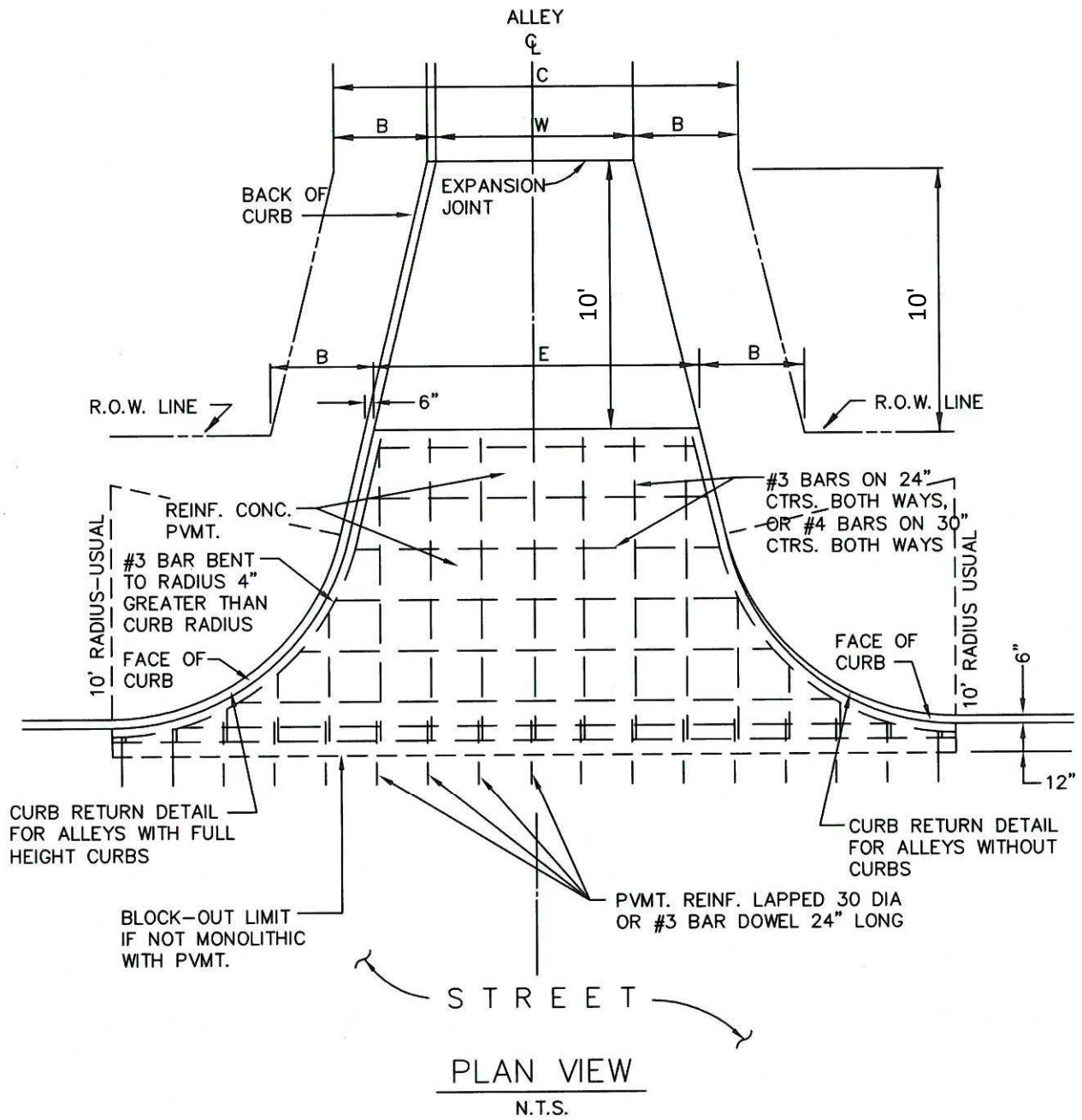

ALLEY WIDTH (W)	R.O.W. WIDTH (C)	B	E
12'	20'	4'	14'

ALLEY APPROACH
RADIUS RETURN TYPE

CITY OF ROCKWALL



STANDARD SPECIFICATION REFERENCE
305.2

DATE
Mar. 2018

STANDARD DRAWING NO.
R-2160

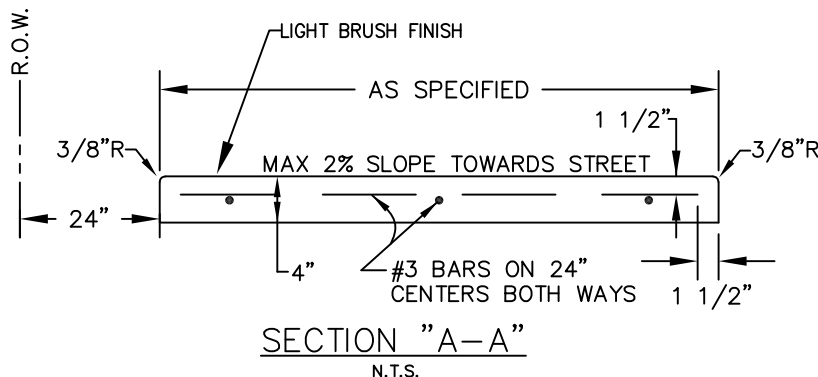
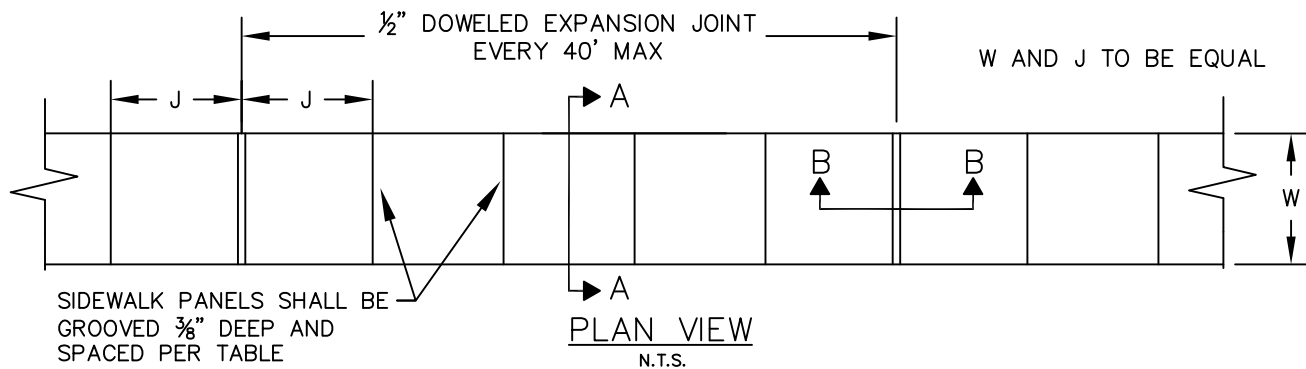

NOTES:

1. CROSS SLOPE OF SIDEWALK SHALL BE NO GREATER THAN 2%
2. SIDEWALK CONCRETE WITHIN CITY R.O.W. SHALL BE MINIMUM 3,000 PSI (5.5 SACK/C.Y.) CONCRETE.
3. ALL SIDEWALKS SHALL MAINTAIN POSITIVE DRAINAGE.
4. ALL HONEYCOMB IN BACK OF CURB TO BE TROWEL-PLASTERED BEFORE POURING SIDEWALK.
5. MINIMUM WIDTH OF 6' IF SIDEWALK ADJACENT TO CURB A LUGGED INTO THE CURB.
6. STEEL WIRE MESH IS NOT ACCEPTABLE.

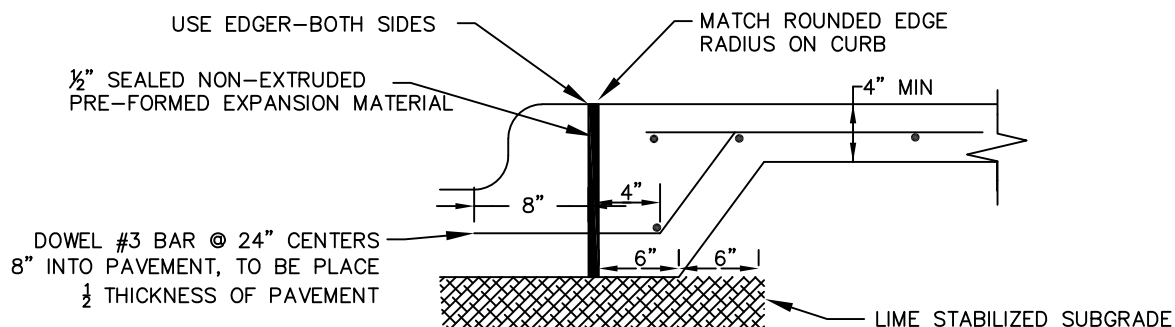
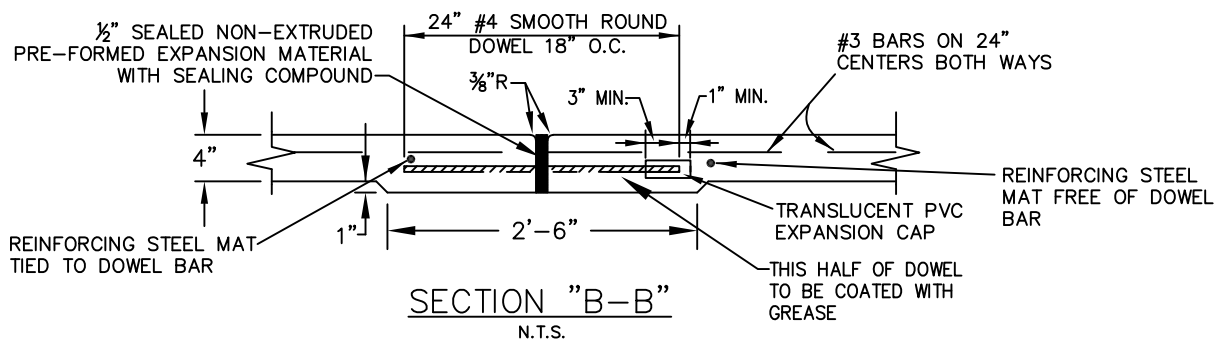

JOINT LUG DETAIL FOR MEDIAN PAVEMENT
LEAD WALK CONNECTIONS OR SIDEWALK ADJACENT TO CURB
N.T.S.

REINFORCED CONCRETE SIDEWALKS

CITY OF ROCKWALL

JOINTS AND SPACING



DATE
AUG '19

DRAWING NO.
R-2170

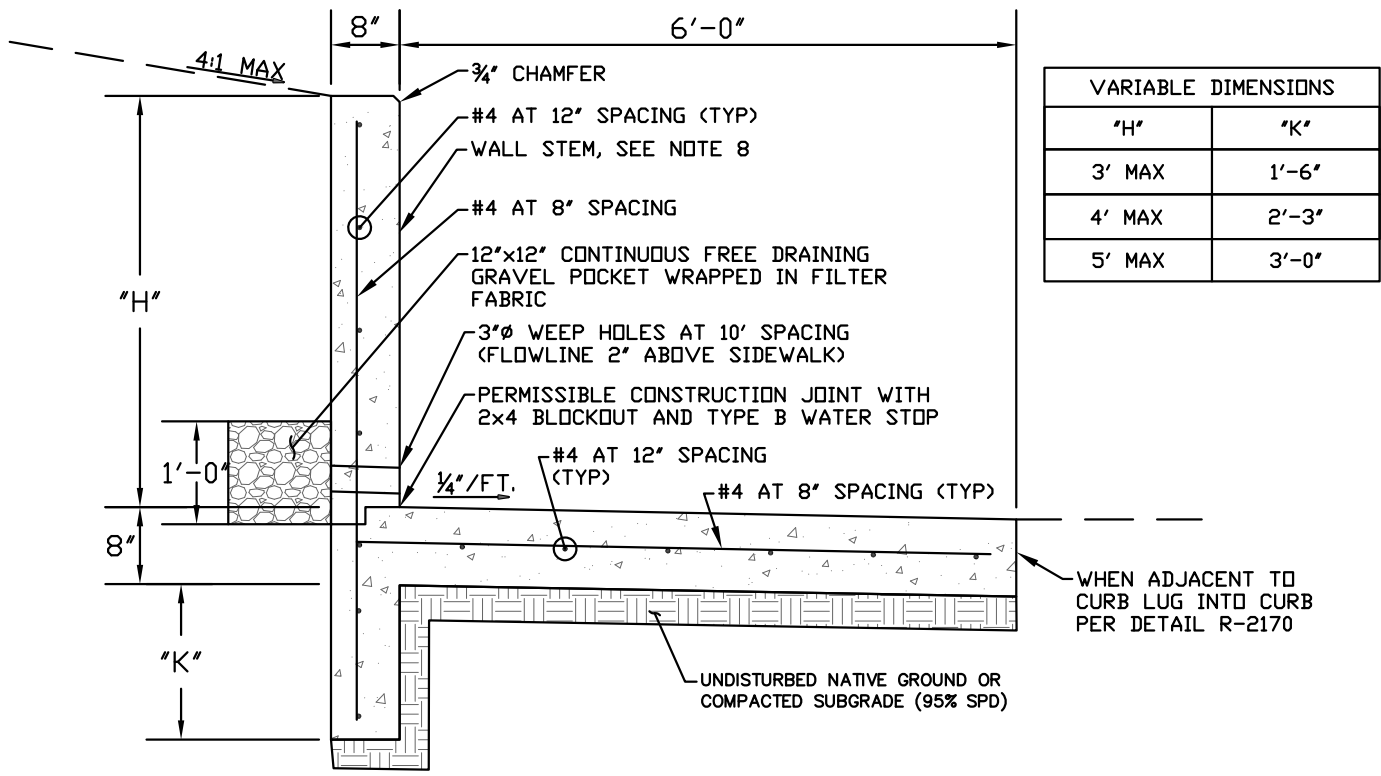

VARIABLE DIMENSIONS	
"H"	"K"
3' MAX	1'-6"
4' MAX	2'-3"
5' MAX	3'-0"

RETAINING WALL WITH INTEGRAL SIDEWALK

N.T.S.

NOTES:

- FOR USE OF THIS STANDARD DETAIL, THE FOLLOWING GEOTECHNICAL SITE CONDITIONS MUST BE MET:
 - MINIMUM ALLOWABLE BEARING PRESSURE: 1,500 PSF
 - MINIMUM COEFFICIENT OF FRICTION: 0.3
 - MAXIMUM ACTIVE PRESSURE COEFFICIENT (K_a): 0.65
- ALL MATERIALS SHALL BE SUBMITTED FOR APPROVAL PRIOR TO CONSTRUCTION.
- ALL CONCRETE SHALL HAVE A MINIMUM COMPRESSIVE STRENGTH OF 4000 PSI.
- ALL REINFORCING STEEL SHALL BE GRADE 60.
- ALL CLEAR COVER SHALL BE 2" WHERE FORMED AND 3" WHERE CAST AGAINST EARTH.
- IF ANY SURCHARGE LOAD IS ANTICIPATED AN ENGINEERING DESIGN IS REQUIRED, SEALED BY A REGISTERED ENGINEER IN THE STATE OF TEXAS. THIS INCLUDES DEAD LOAD SURCHARGES AND LIVE LOAD SURCHARGES SUCH AS TRAFFIC LOADS.
- JOINT LOCATIONS SHALL MATCH ON SIDEWALK AND WALL. JOINT SPACING SHALL BE EVERY 30 FEET FOR CONTROL JOINTS AND EVERY 90 FEET FOR EXPANSION JOINTS. TYPE B WATERSTOP SHALL BE APPLIED ON THE FILL SIDE OF ALL EXPANSION AND CONSTRUCTION JOINTS.
- WALL FACE SHALL BE FORM LINER OR STONE VENEER WITH RANDOM ROCK ASHLAR PATTERN, NO SMOOTH CONCRETE SURFACE ALLOWED

REINFORCED CONCRETE RETAINING WALL	CITY OF ROCKWALL		
INTEGRAL WITH SIDEWALK		DATE	DRAWING NO.
		AUG '19	R-2180

GENERAL NOTES:

1. REINFORCED CONCRETE PAVEMENT:
 - A. ALL CURBS SHALL BE PLACED INTEGRAL WITH PAVEMENT UNLESS OTHERWISE APPROVED BY THE OWNER.
 - B. CURBS SHALL MEET THE SAME COMPRESSIVE STRENGTH AS SPECIFIED FOR THE PAVEMENT.
 - C. BAR LAPS SHALL BE 30 DIAMETERS.
 - D. REINFORCING BARS SHALL BE SUPPORTED BY CHAIRS OR OTHER DEVICES APPROVED BY THE OWNER.

2. SUBGRADE: (UNLESS OTHERWISE SPECIFIED BY OWNER)
 - A. SUBGRADE UNDER ALL PAVEMENTS SHALL BE STABILIZED TO A MINIMUM DEPTH OF SIX (6") INCHES WITH HYDRATED LIME CEMENT. LABORATORY TESTS WILL BE PERFORMED TO DETERMINE THE AMOUNT OF LIME OR CEMENT TO USE.

PAVEMENT SYSTEMS	CITY OF ROCKWALL	STANDARD SPECIFICATION REFERENCE 302,303	
GENERAL NOTES		DATE Mar. 2018	STANDARD DRAWING NO. R-2190

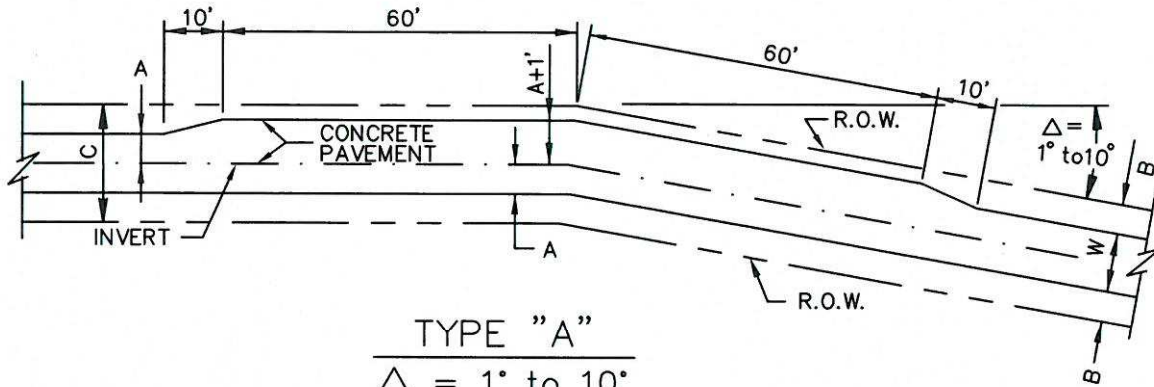

TYPE "A"
 $\Delta = 1^\circ \text{ to } 10^\circ$
 N.T.S.

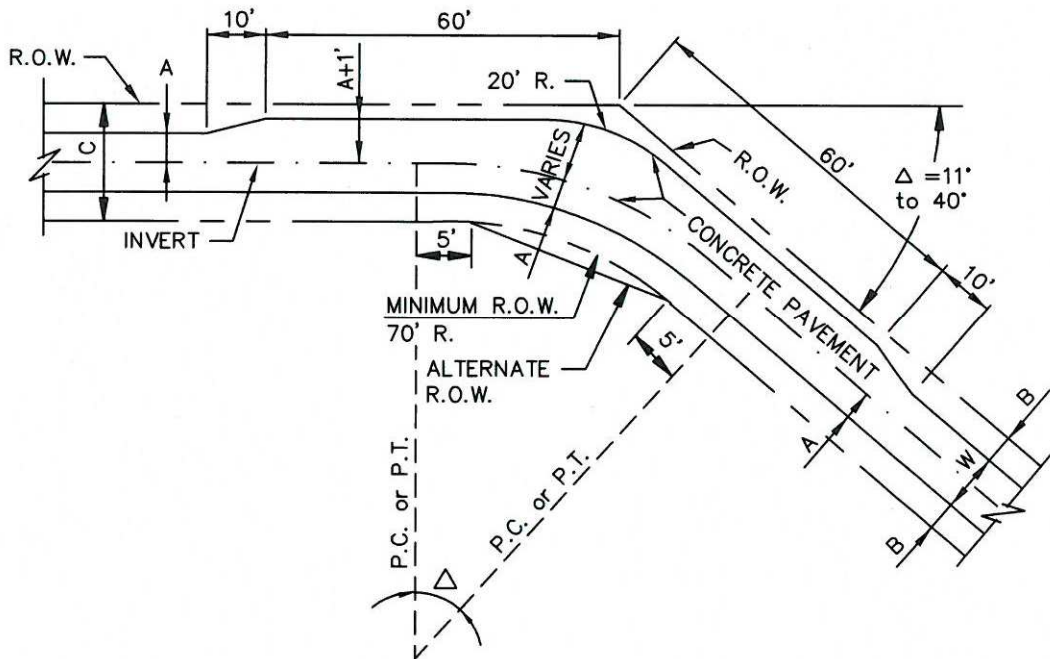

TYPE "B"
 $\Delta = 11^\circ \text{ to } 40^\circ$
 N.T.S.

NOTES:

1. ALLEY WIDTH SHALL BE TWELVE (12') FEET MINIMUM.
2. ALLEY R.O.W. SHALL BE TWENTY (20') FEET MINIMUM.
3. DIMENSION A= SIX (6') FEET.
4. DIMENSION B= FOUR (4') FEET.

ALLEY GEOMETRICS

TYPE "A" & TYPE "B"

CITY OF ROCKWALL



STANDARD SPECIFICATION REFERENCE
 303.5

DATE
 Mar. 2018

STANDARD DRAWING NO.
 R-2210

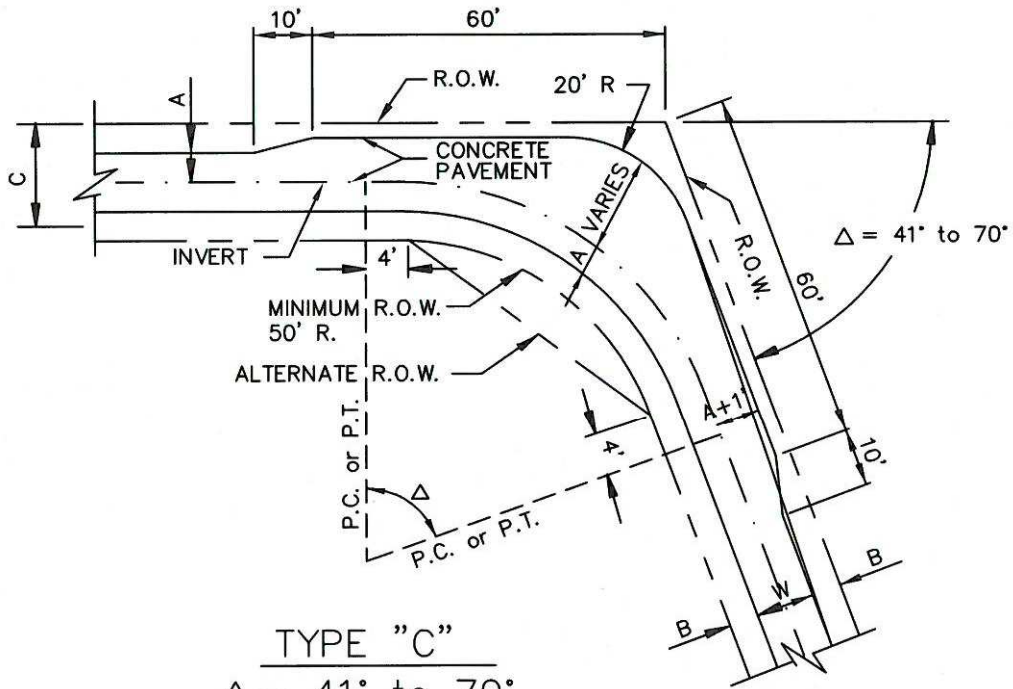

TYPE "C"
 $\Delta = 41^\circ$ to 70°
 N.T.S.

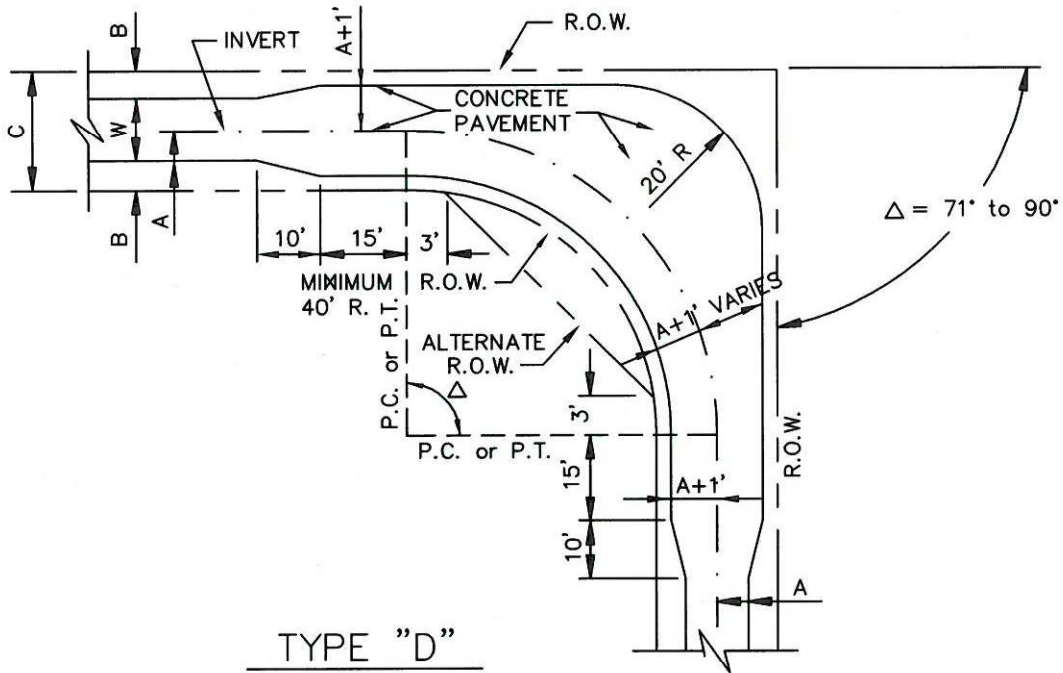

TYPE "D"
 $\Delta = 71^\circ$ to 90°
 N.T.S.

NOTES:

1. ALLEY WIDTH SHALL BE TWELVE (12') FEET MINIMUM.
2. ALLEY R.O.W. SHALL BE TWENTY (20') FEET MINIMUM.
3. DIMENSION A= SIX (6') FEET.
4. DIMENSION B= FOUR (4') FEET.

ALLEY GEOMETRICS

TYPE "C" & TYPE "D"

CITY OF ROCKWALL



STANDARD SPECIFICATION REFERENCE

303.5

DATE

Mar. 2018

STANDARD DRAWING NO.

R-2220

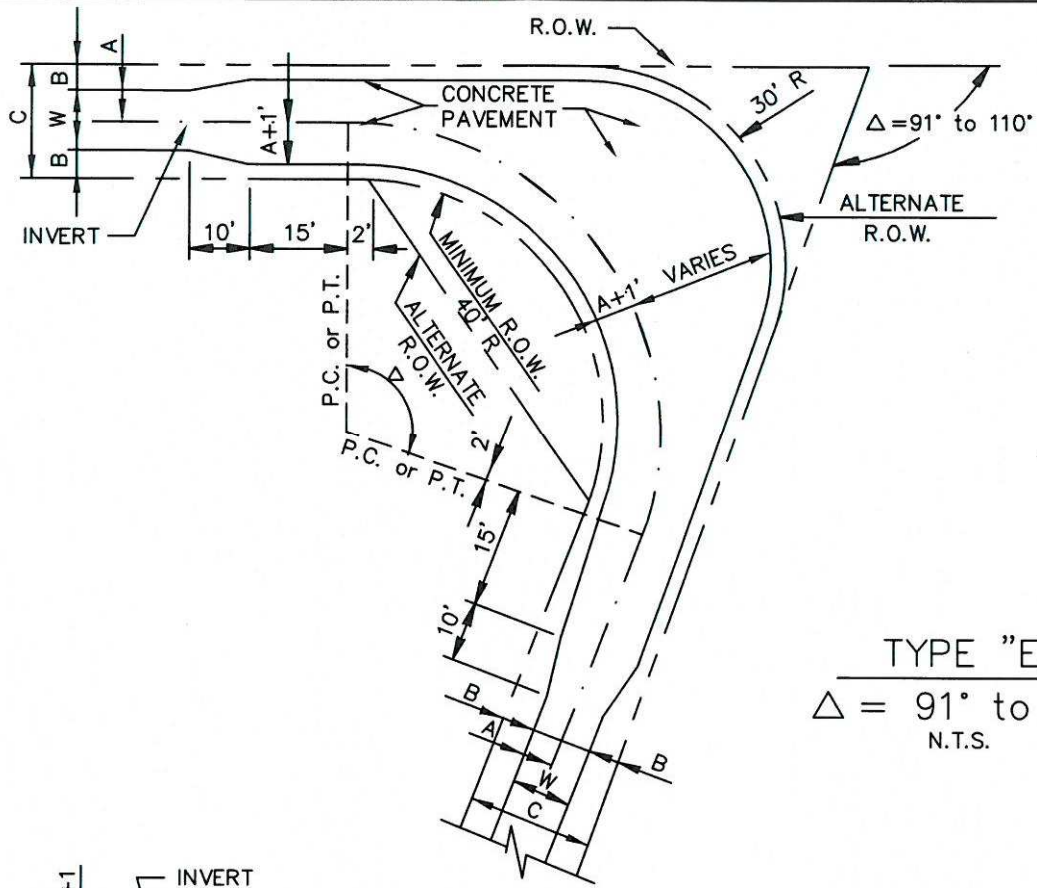

TYPE "E"
 $\Delta = 91^\circ \text{ to } 110^\circ$
 N.T.S.

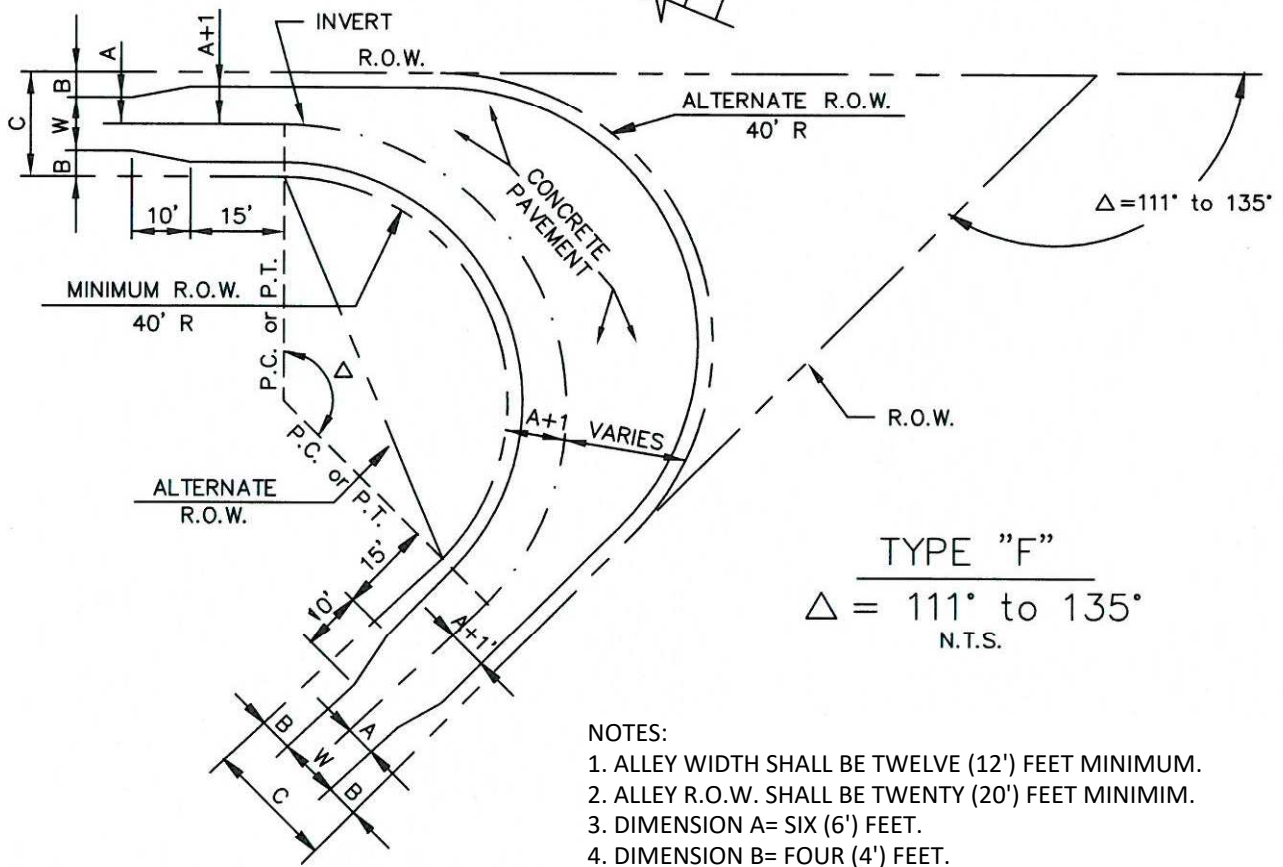

TYPE "F"
 $\Delta = 111^\circ \text{ to } 135^\circ$
 N.T.S.

- NOTES:
1. ALLEY WIDTH SHALL BE TWELVE (12') FEET MINIMUM.
 2. ALLEY R.O.W. SHALL BE TWENTY (20') FEET MINIMUM.
 3. DIMENSION A= SIX (6') FEET.
 4. DIMENSION B= FOUR (4') FEET.

ALLEY GEOMETRICS	CITY OF ROCKWALL	STANDARD SPECIFICATION REFERENCE 303.5
TYPE "E" & TYPE "F"		DATE Mar. 2018 STANDARD DRAWING NO. R-2230

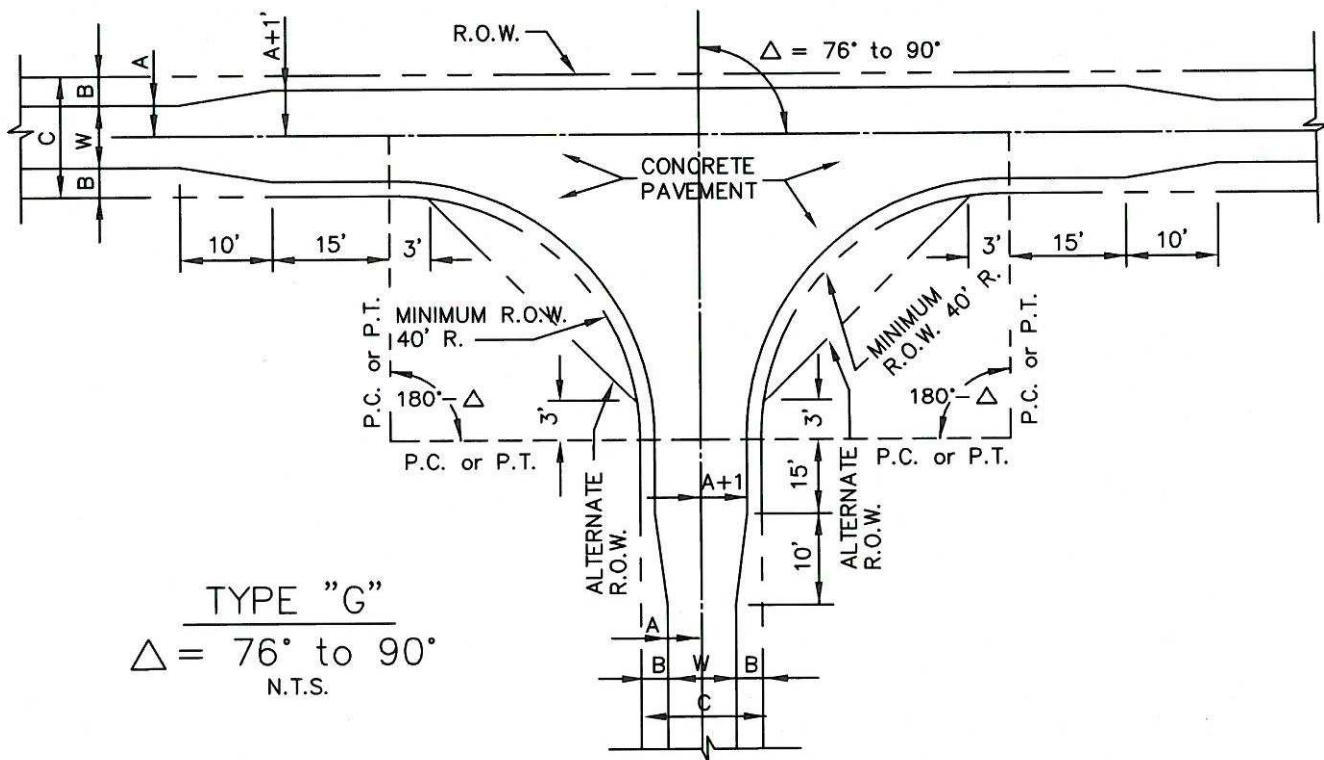

TYPE "G"
 $\Delta = 76^\circ \text{ to } 90^\circ$
 N.T.S.

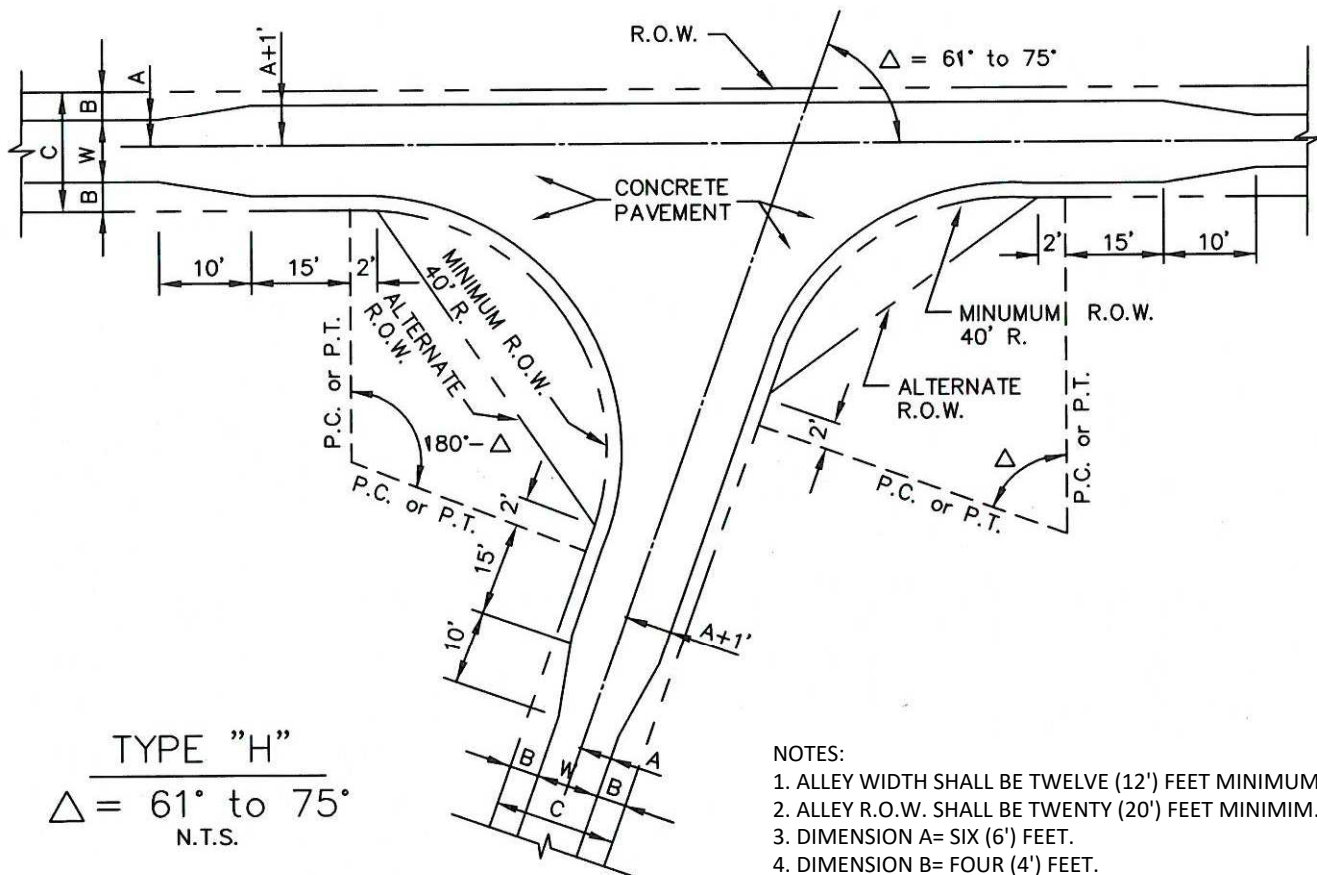

TYPE "H"
 $\Delta = 61^\circ \text{ to } 75^\circ$
 N.T.S.

NOTES:

1. ALLEY WIDTH SHALL BE TWELVE (12') FEET MINIMUM.
2. ALLEY R.O.W. SHALL BE TWENTY (20') FEET MINIMUM.
3. DIMENSION A= SIX (6') FEET.
4. DIMENSION B= FOUR (4') FEET.

ALLEY GEOMETRICS

TYPE "G" & TYPE "H"

CITY OF ROCKWALL



STANDARD SPECIFICATION REFERENCE

303.5

DATE

Mar. 2018

STANDARD DRAWING NO.

R-2240

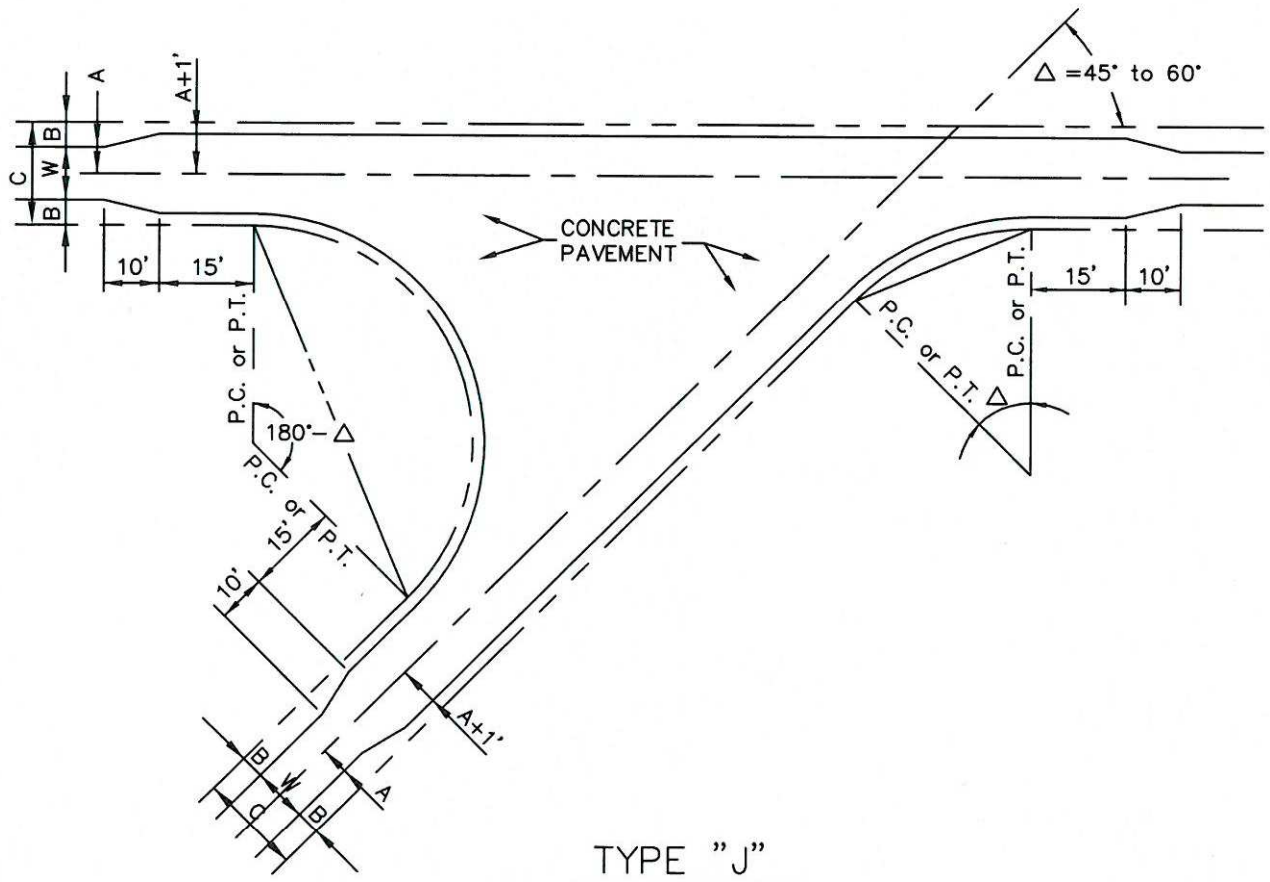

TYPE "J"
 $\Delta = 45^\circ \text{ to } 60^\circ$
 N.T.S.

NOTES:

1. ALLEY WIDTH SHALL BE TWELVE (12') FEET MINIMUM.
2. ALLEY R.O.W. SHALL BE TWENTY (20') FEET MINIMUM.
3. DIMENSION A= SIX (6') FEET.
4. DIMENSION B= FOUR (4') FEET.

ALLEY GEOMETRICS

TYPE "J"

CITY OF ROCKWALL



STANDARD SPECIFICATION REFERENCE

303.5

DATE
 Mar. 2018

STANDARD DRAWING NO.
 R-2250

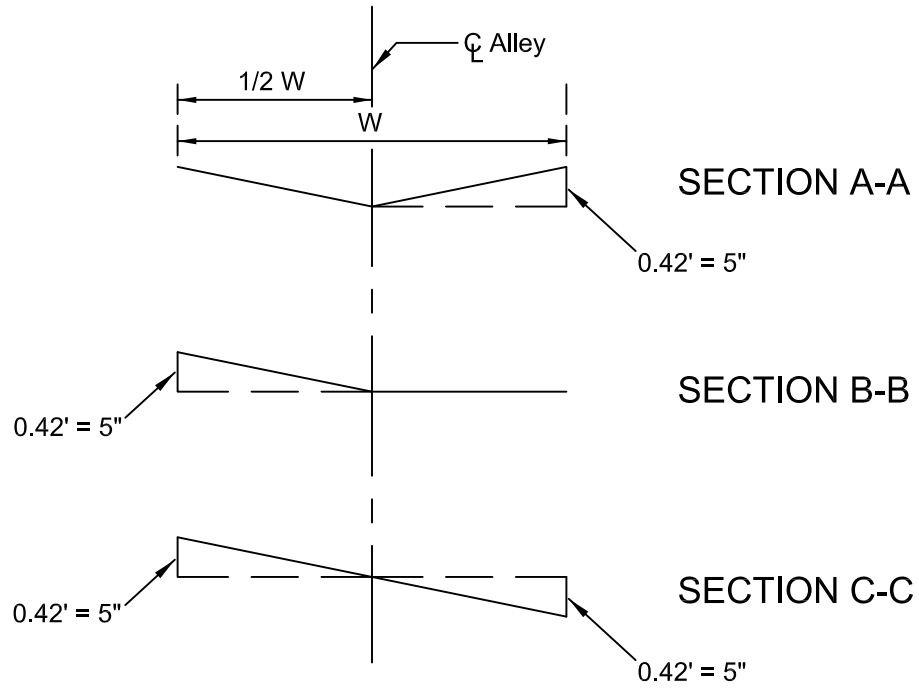
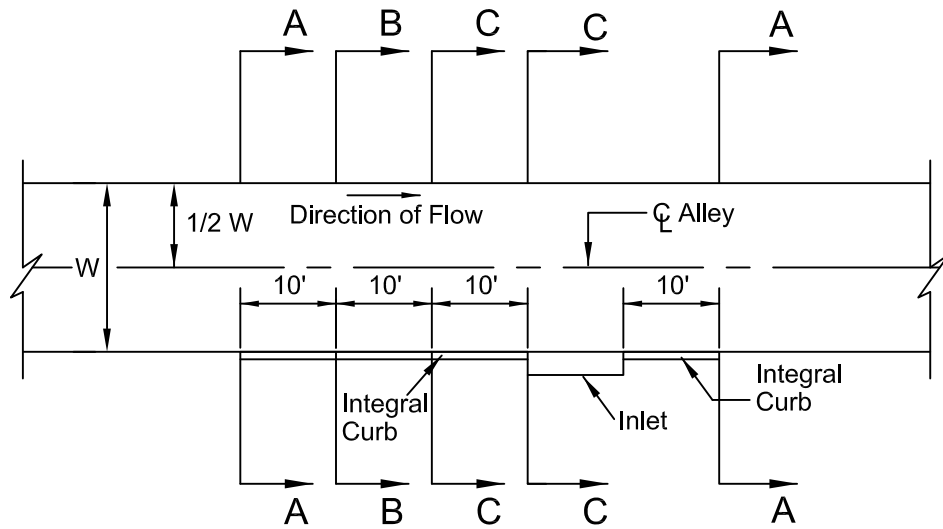

TYPICAL ALLEY WARPING AT INLET
(Not to Scale)

ALLEY GEOMETRICS

CITY OF ROCKWALL

ALLEY WARPING AT INLET



DATE
OCT. '17

DRAWING NO.
R-2251

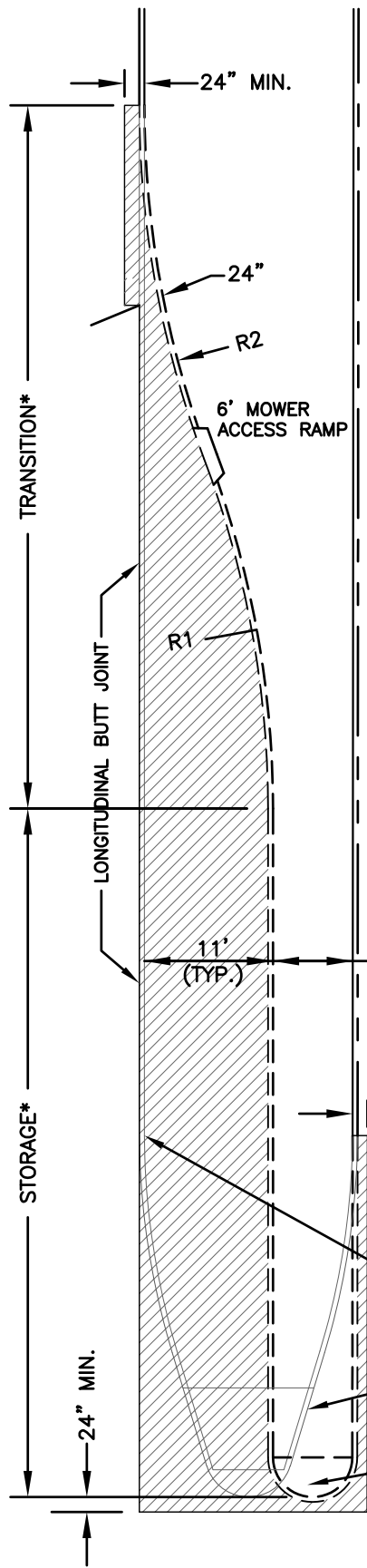

NOTES:

1. ALL DIMENSIONS ARE TO BACK OF CURB UNLESS OTHERWISE NOTED.
2. NO CONCRETE REPLACEMENT WIDTH SHALL BE LESS THAN 24".
3. PAVEMENT SECTION SHALL MATCH THAT OF EXISTING STREET.
4. ALL TIEBARS FOR LONGITUDINAL CONSTRUCTION JOINTS SHALL BE MACHINE DRILLED. NO HAND DRILLING ALLOWED.
5. IF MEDIAN WIDTH $\leq 7'$ (FACE TO FACE) THEN 6" THICK REINFORCED INTEGRAL STAINED AND STAMPED COLOR CONCRETE MEDIAN PAVEMENT SHALL BE INSTALLED.
6. ALL SAWCUTS TO BE FULL DEPTH AND EITHER PERPENDICULAR AND/OR PARALLEL WITH STREET CENTERLINE. NO ANGLED OR CURVED SAWCUTS ALLOWED.
7. WHEN SAWCUT EXCEEDS HALF OF CONSTRUCTION JOINT PANEL WIDTH, FULL PANEL REMOVAL AND REPLACEMENT SHALL BE REQUIRED.
8. TYPICAL R1/R2 VALUES:
 250' TYP. FOR SINGLE TURN LANE
 250' TYP. FOR DUAL TURN LANE
9. MUST MATCH JOINTS OF ADJACENT TRAFFIC LANES

* REFER TO CONSTRUCTION DRAWINGS FOR STORAGE, TRANSITION AND RADII DIMENSIONS.

LEFT TURN LANE

CITY OF ROCKWALL

CONCRETE REMOVAL & REPLACEMENT



DATE
AUG. '19

DRAWING NO.
R-2270

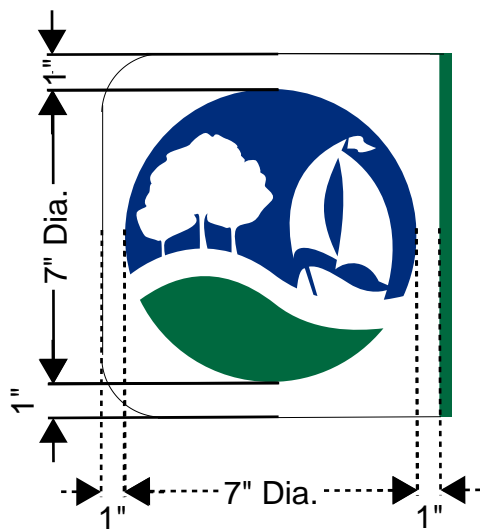

Rockwall Logo Detail

NOT TO SCALE

Notes:

1. Street name blades shall consist of white SCOTCHLITE 3930 High Intensity Prismatic Material, digitally printed using HP Latex 360 or higher.
 Green: Pantone 335C with overlay CMYK 100-0-20-0 set to darken.
 Blue: Pantone 287C.

2. Lettering to be composed of a combination of upper and lowercase letters, with initial uppercase letters. Font to be Clearview TCAD-1w with uppercase to be 6" Min. height and lowercase to be 4.5" Min. height. No more than 65% compression on font width.

3. Lettering for street designations and block numbers to be composed of initial uppercase letters at least 3" Min. height and lower-case letters at least 2.25" Min. height.

STREET SIGN DETAIL

NOT TO SCALE

STREET REGULATORY SIGNAGE	CITY OF ROCKWALL		
TYPICAL STREET SIGN DETAIL		DATE May 2018	DRAWING NO. R-2300



**EXAMPLE SINGLE STREET
NAME DETAIL**

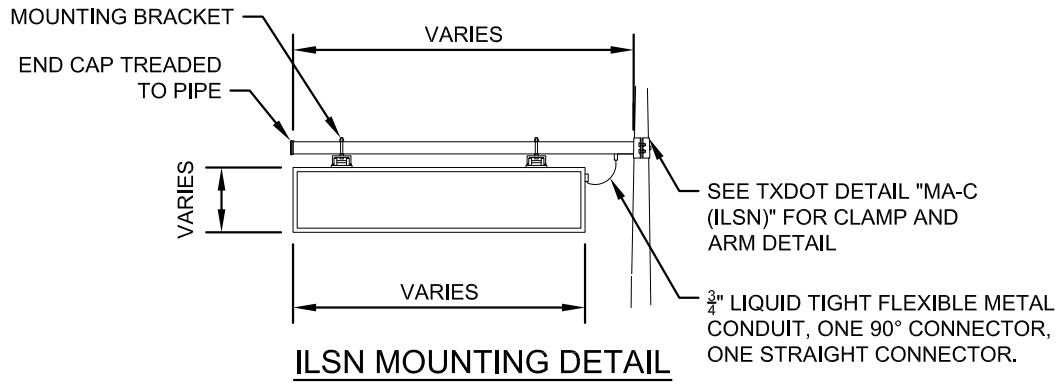

NOTES:

1. UNLESS OTHERWISE SPECIFIED, ALL LETTER SPACING AND WIDTH SHALL BE 100% OF THE US DOT MINIMUM RECOMMENDATION.
 - A. LEGENDS REQUIRING LENGTHS GREATER THAN THE 96" WIDTH OF THE SIGN USING STANDARD SPACING, MAY BE ADJUSTED TO FIT.
2. ILSNS UP TO 6' IN LENGTH MAY BE PLACED ON A 7' ILSN CLAMP-ON ARM. ILSNS UP TO 8' IN LENGTH MAY BE PLACED ON A 9' ILSN CAMP-ON ARM.
3. LETTERING SIZE AND SPACING BETWEEN THE VARIOUS SIGN ELEMENTS SHALL FOLLOW THE CURRENT VERSION OF THE *STANDARD HIGHWAY SIGN DESIGNS FOR TEXAS* MANUAL FOR D3-1.
 - A. DESIRED LETTER HEIGHT FOR STREET NAME SIGNS SHALL BE 12" FOR UPPER CASE LETTERS. STREET NAME LETTER HEIGHT MAY BE REDUCED TO 10" TO REDUCE THE SIZE OF THE SIGN AS NEEDED.
4. THE CITY LOGO HEIGHT SHALL MATCH MAXIMUM TEXT SIZE HEIGHT ON SIGN LEGEND. THE LOGO SHALL BE PLACED ON THE LEFT SIDE OF EACH SIDE OF THE SIGN ON A WHITE BACKGROUND.
5. THE ILSN LEGEND MAY BE COMPOSED OF ONE LINE OR TWO LINES OF TEXT. CONTRACTOR TO VERIFY WITH CITY BEFORE SUBMITTING SHOP DRAWINGS FOR SIGNS WITH TWO LINES OF TEXT.
6. SIGNS SHALL BE EDGELIT LED ILLUMINATED
7. FACE COLOR/MATERIAL: GREEN EC FILM OVER HIGH-INTENSITY TRANSLUCENT REFLECTIVE WHITE SHEETING ON UV LEXAN.
8. FRAME WIDTH TO BE PROVIDED BY MANUFACTURER.
9. SIGN BODIES AND DOORS ARE TO BE POWDER COATED GLOSSY BLACK.
10. SIGNS SHALL BE SINGLE SIDED EXCEPT UNDER THE FOLLOWING CONDITION:
SIGN SHALL BE DOUBLE SIDED IF BOTH APPROACHES FACING THE SIGN ARE UNDIVIDED(NO MEDIAN).
11. SIGNS SHALL BE TOP MOUNTED USING STANDARD TXDOT DETAILS.
12. ILSN SHALL BE MOUNTED ON A STANDARD TXDOT ILSN CLAMP-ON ARM UNLESS OTHERWISE DIRECTED IN THE PLANS
13. ILSN SHALL BE FULLY GASKETED AND WATERTIGHT.
14. TRAFFIC SIGNAL POLE SHALL BE AT LEAST 24' HEIGHT. (SEE TXDOT TRAFFIC SIGNAL POLE STANDARDS)
15. A SEPARATE PHOTOCELL FOR ILSN/120 VOLT CIRCUIT WILL BE REQUIRED.
16. TWO #8 XHHW CONDUCTORS SHALL BE INSTALLED FROM SERVICE TO TERMINAL BLOCK OF EACH POLE WITH ILSN UNLESS OTHERWISE SHOWN IN THE PLANS. (CONDUCTORS FROM SERVICE TO TERMINAL BLOCK OF EACH POLE SHALL BE PAID FOR SEPARATELY FROM THE ILSN PAY ITEM.)
 - A. DAISY CHAIN ALL ILSNS UNLESS OTHERWISE DIRECTED IN THE PLANS.
17. TWO # 12 XHHW CONDUCTORS SHALL BE INSTALLED FROM TERMINAL BLOCK OF POLE TO ILSN UNLESS OTHERWISE SHOWN IN THE PLANS. (CONDUCTORS FROM THE TERMINAL BLOCK OF EACH POLE TO ILSN SHALL BE PAID FOR SEPARATELY FROM THE ILSN PAY ITEM.)
18. CONTRACTOR TO SUBMIT SHOP DRAWINGS OF THE LED ILSNS TO CITY OF ROCKWALL FOR APPROVAL PRIOR TO FABRICATION.
19. CONTRACTOR SHALL BE RESPONSIBLE FOR ALL EQUIPMENT NECESSARY TO INSTALL THE ILSN SIGN.
20. ALL ISLNS SHALL FOLLOW ALL RULES AND GUIDELINES AS SPECIFIED IN THE MOST RECENT EDITIONS OF THE *STANDARD HIGHWAY SIGN DESIGNS FOR TEXAS* AND THE *TEXAS MANUAL ON UNIFORM TRAFFIC CONTROL DEVICES*. SHOULD ANY CONFLICTS BETWEEN THE ABOVE NOTES AND THESE DOCUMENTS, THESE DOCUMENTS SHALL GOVERN.

ILLUMINATED STREET NAME SIGN	CITY OF ROCKWALL 			
ILSN SIGN DETAIL		<table border="1" style="width: 100%; border-collapse: collapse;"> <tr> <td style="width: 50%; padding: 2px;">DATE JUN '17</td> <td style="width: 50%; padding: 2px;">DRAWING NO. R-2310</td> </tr> </table>	DATE JUN '17	DRAWING NO. R-2310
DATE JUN '17	DRAWING NO. R-2310			

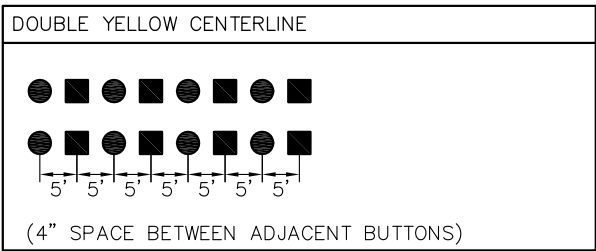
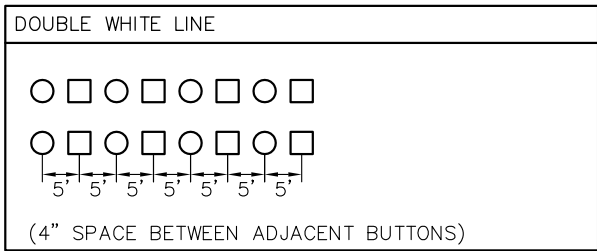
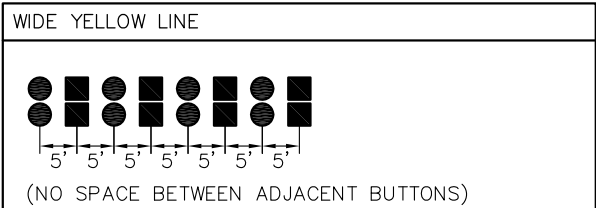
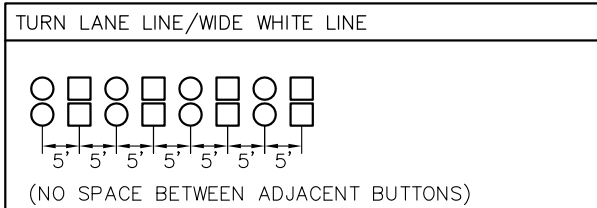
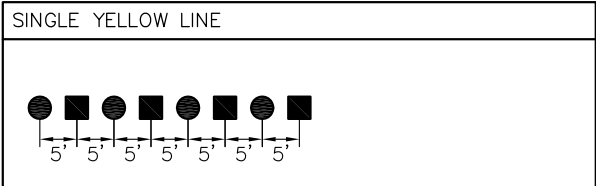
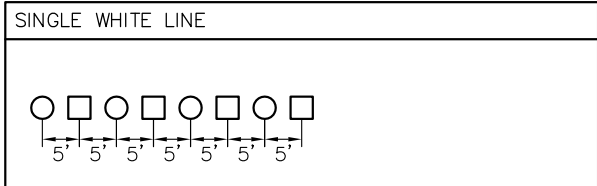
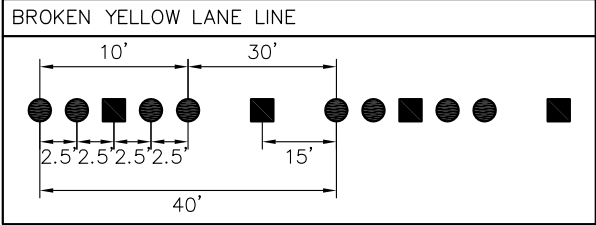
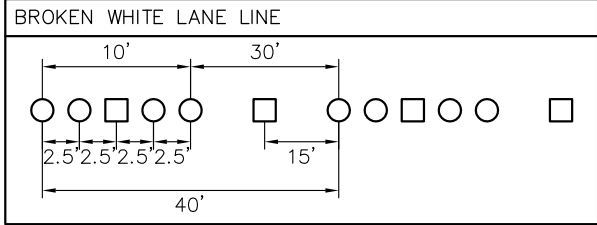

- NOTES:
- UNLESS OTHERWISE NOTED, THE FOLLOWING BUTTON TYPES SHALL BE USED:
- = 4" ROUND YELLOW CERAMIC NON-REFLECTIVE BUTTON
 - = 4" SQUARE YELLOW/YELLOW ACRYLIC REFLECTIVE BUTTON
 - = 4" ROUND WHITE CERAMIC NON-REFLECTIVE BUTTON
 - = 4" SQUARE CLEAR/RED ACRYLIC REFLECTIVE BUTTON

RAISED PAVEMENT MARKINGS

LANE LINES



STANDARD SPECIFICATION REFERENCE	
DATE	STANDARD DRAWING NO.
Mar. 2018	R-2320

*Section II Standard Drawings as of October 2004. Reference number only has been updated for Fifth Edition Specifications. *Public Works Construction Standards North Central Texas, Fifth Edition.*

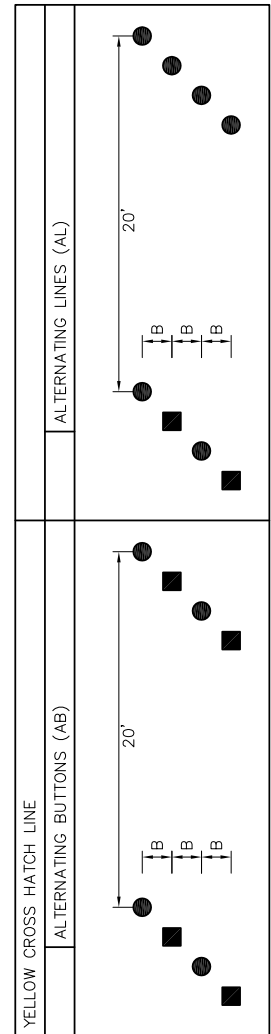
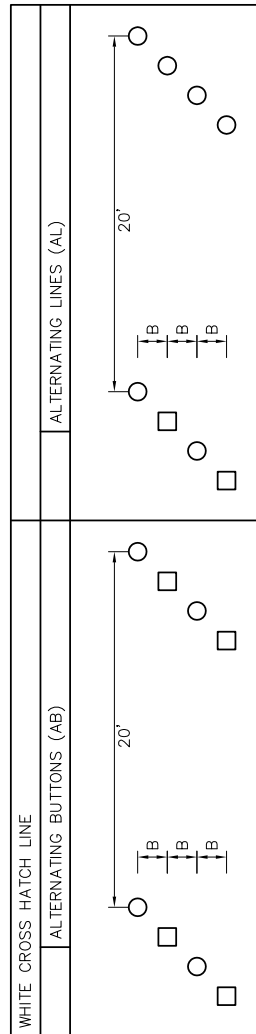
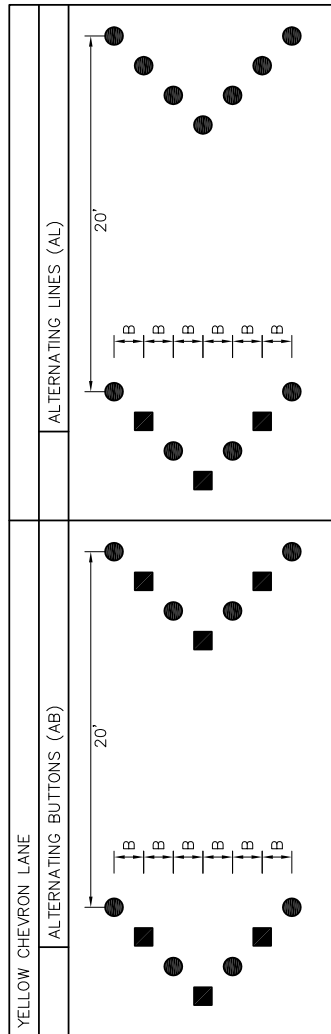
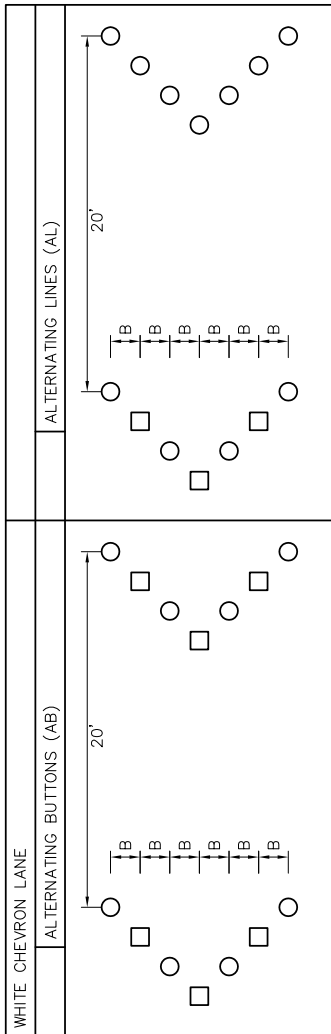

NOTES:
UNLESS OTHERWISE NOTED, THE FOLLOWING BUTTON TYPES SHALL BE USED:

- = 4" ROUND YELLOW CERAMIC NON-REFLECTIVE BUTTON
- = 4" SQUARE YELLOW/YELLOW ACRYLIC REFLECTIVE BUTTON
- = 4" ROUND WHITE CERAMIC NON-REFLECTIVE BUTTON
- = 4" SQUARE CLEAR/RED ACRYLIC REFLECTIVE BUTTON

FOR CHEVRON AND CROSS-HATCH LINES, THE FOLLOWING DIMENSIONS WILL BE NOTED ON THE PLANS.

B = THE DISTANCE BETWEEN ADJACENT BUTTONS ON A LINE (MEASURED ALONG A LINE PERPENDICULAR TO THE BUTTONED AREA, NOT ALONG THE 45 DEGREE LINE)

RAISED PAVEMENT MARKINGS
CHEVRON AND CROSSHATCH



STANDARD SPECIFICATION REFERENCE	
DATE Mar. 2018	STANDARD DRAWING NO. R-2330

*Section II Standard Drawings as of October 2004. Reference number only has been updated for Fifth Edition Specifications. *Public Works Construction Standards North Central Texas, Fifth Edition.*

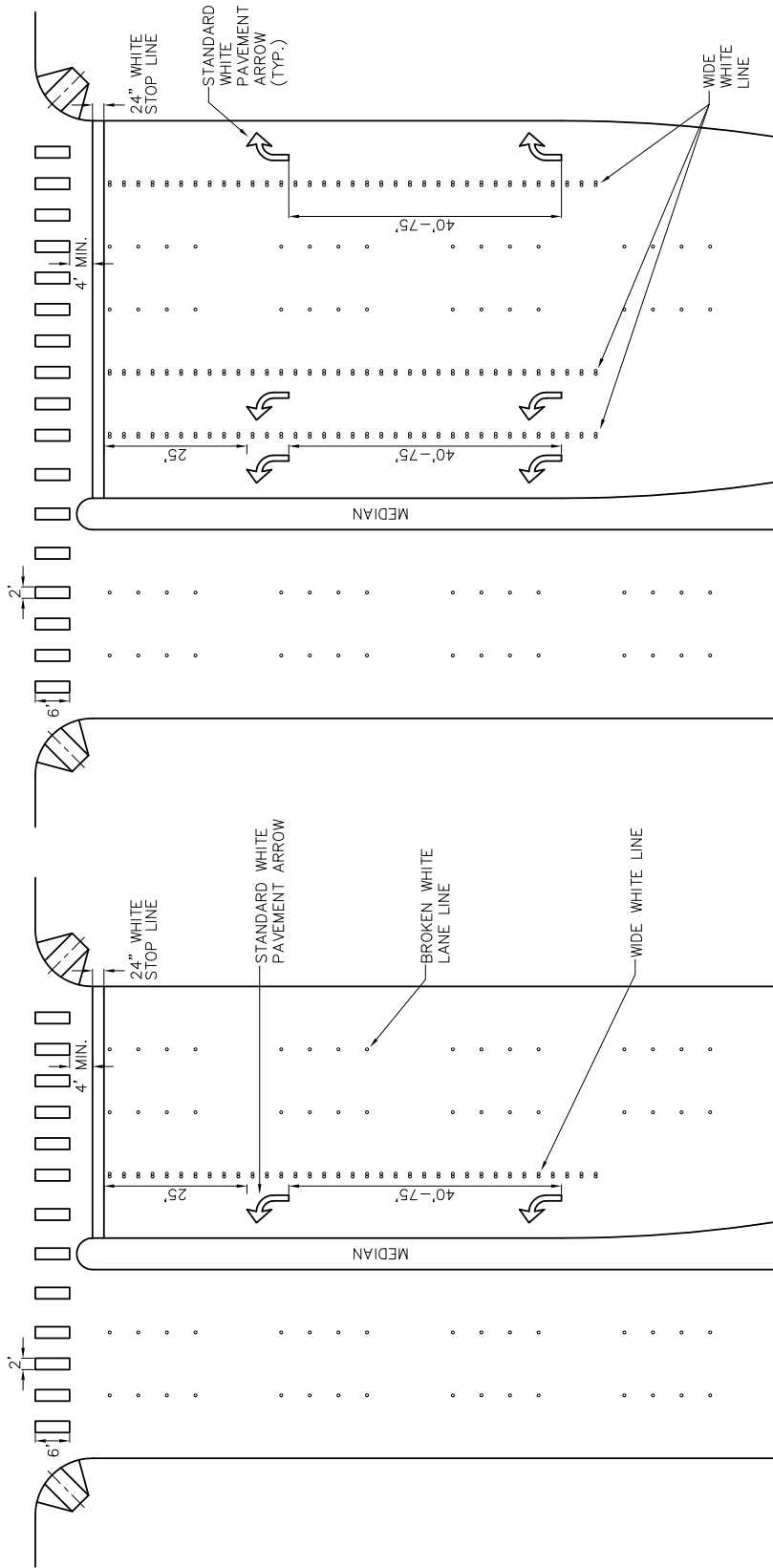

DUAL LEFT TURN LANE & RIGHT TURN LANE

TYPICAL APPROACH

RAISED PAVEMENT MARKINGS
INTERSECTION APPROACH

CITY OF ROCKWALL



STANDARD SPECIFICATION REFERENCE

DATE
Mar. 2018

STANDARD DRAWING NO.
R-2340

*Section II Standard Drawings as of October 2004. Reference number only has been updated for Fifth Edition Specifications. *Public Works Construction Standards North Central Texas, Fifth Edition.*

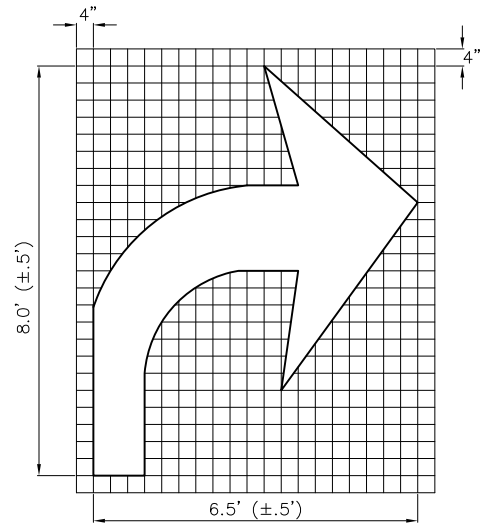
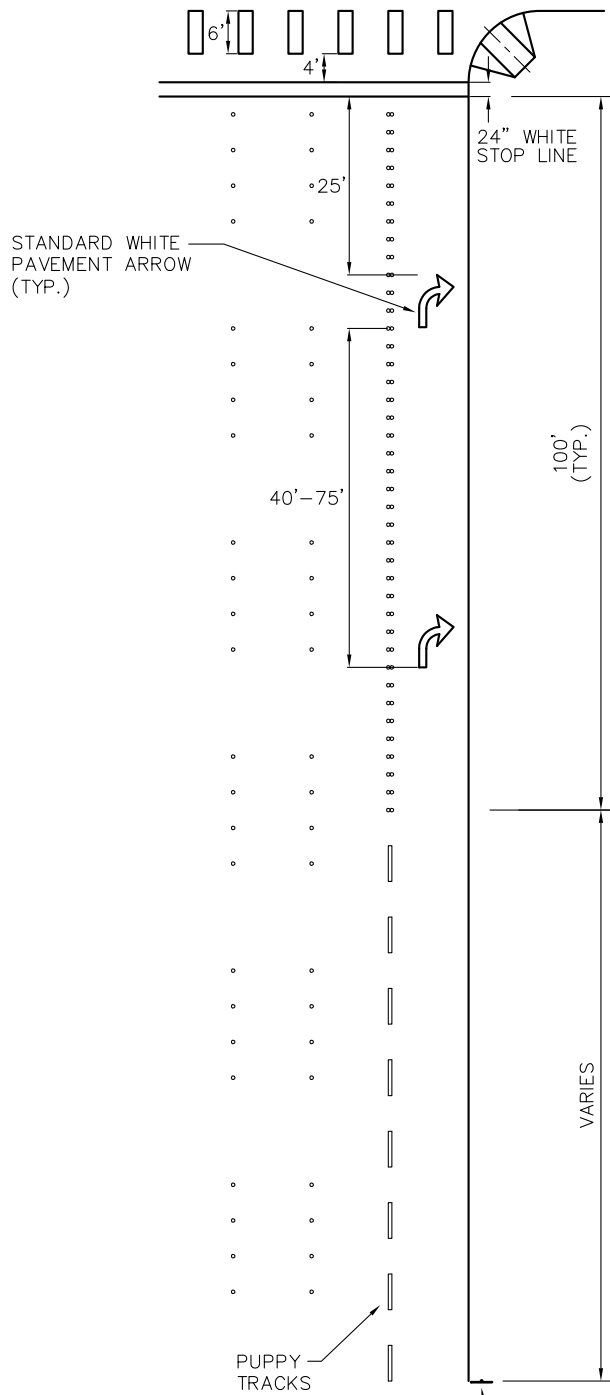

TURN ARROW

RIGHT LANE
MUST
TURN RIGHT

R3-7R

TYPE C INTERSECTION

RIGHT LANE DROP MARKINGS

CITY OF ROCKWALL



STANDARD SPECIFICATION REFERENCE

DATE
Mar. 2018

STANDARD DRAWING NO.
R-2350

*Section II Standard Drawings as of October 2004. Reference number only has been updated for Fifth Edition Specifications. *Public Works Construction Standards North Central Texas, Fifth Edition.*

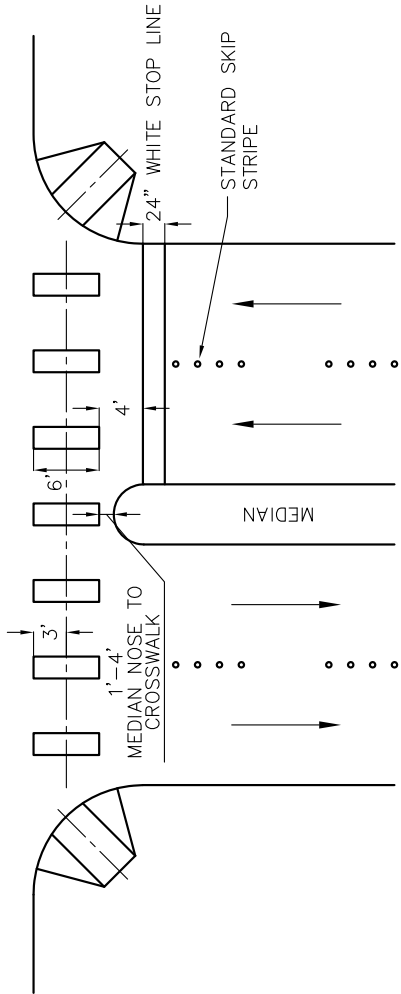

TYPICAL LAYOUT
 TYPE D THOROUGHFARE
 STOP LINE WITH CROSSWALK

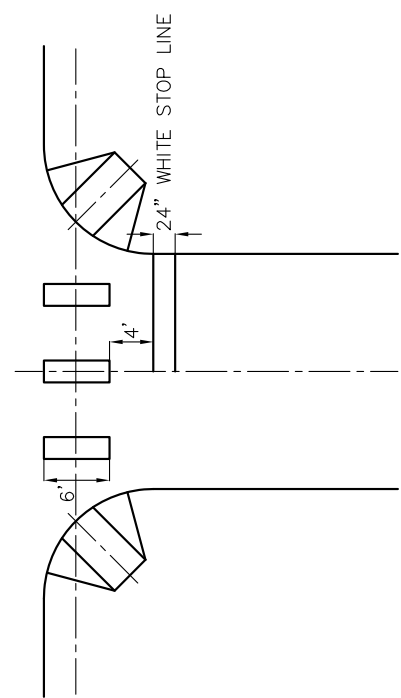

TYPICAL LAYOUT
 TYPE F&G THOROUGHFARE
 CROSSWALK WITH STOP LINE

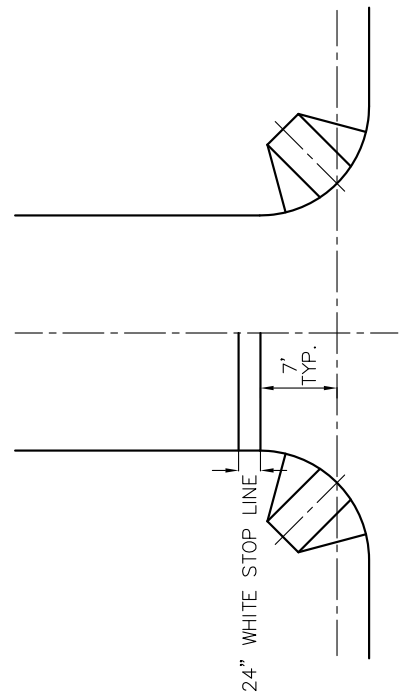

TYPICAL LAYOUT
 TYPE F&G THOROUGHFARE
 STOP LINE WITHOUT CROSSWALK

TYPICAL THOROUGHFARE
 LAYOUTS



STANDARD SPECIFICATION REFERENCE	
DATE Mar. 2018	STANDARD DRAWING NO. R-2360

*Section II Standard Drawings as of October 2004. Reference number only has been updated for Fifth Edition Specifications. *Public Works Construction Standards North Central Texas, Fifth Edition.*

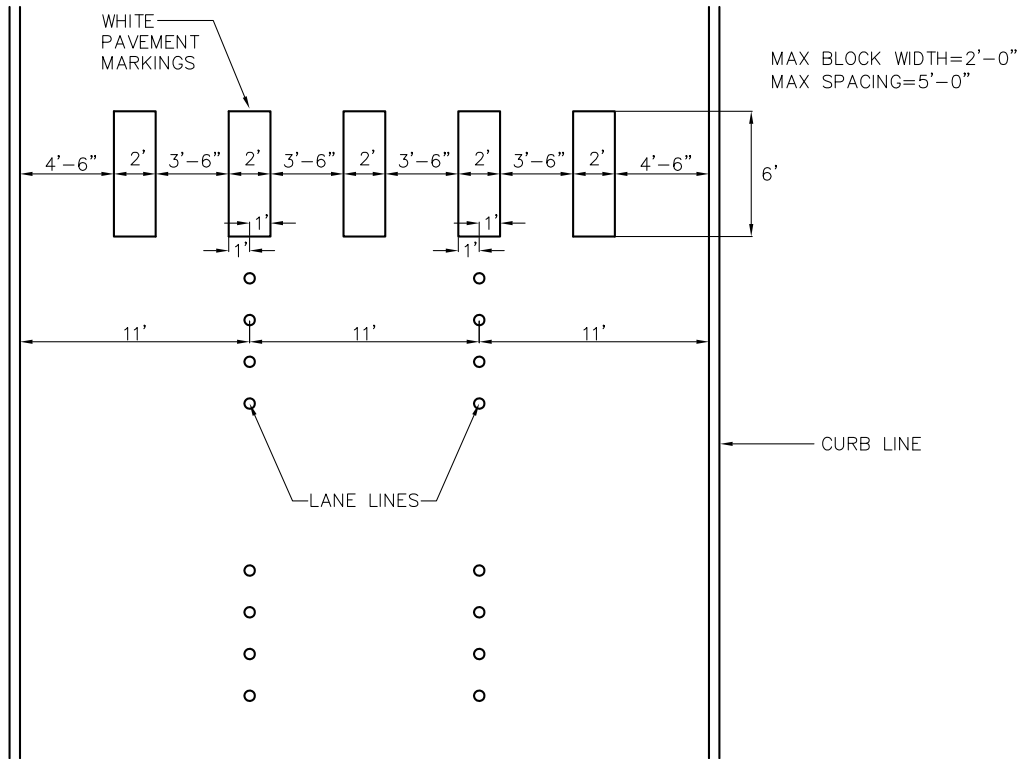

TYPICAL LAYOUT
CROSSWALK
MARKINGS

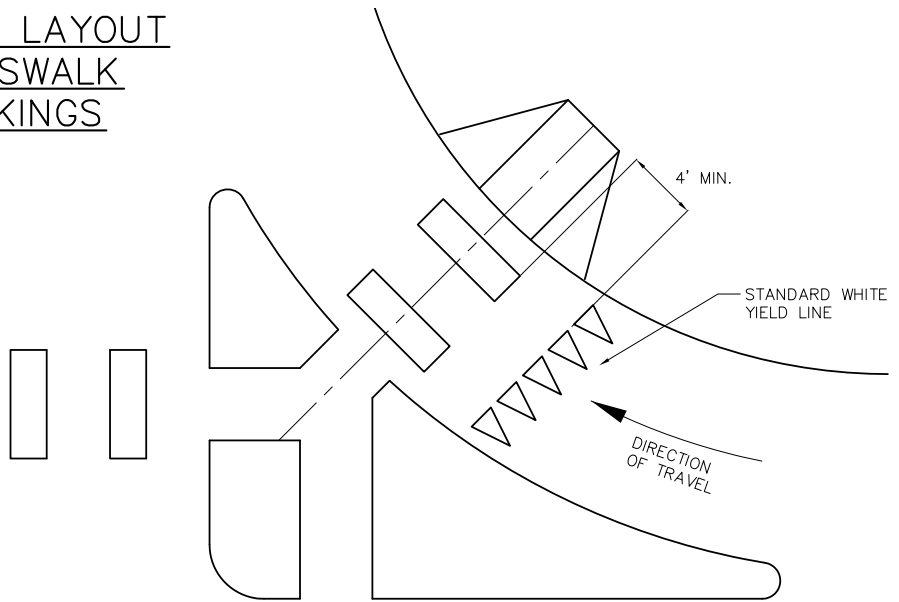

TYPICAL LAYOUT
CHANNELIZING ISLAND
YIELD LINE WITH CROSSWALK

TYPICAL CROSSWALK LAYOUTS	CITY OF ROCKWALL	STANDARD SPECIFICATION REFERENCE	
		DATE Mar. 2018	STANDARD DRAWING NO. R-2370

*Section II Standard Drawings as of October 2004. Reference number only has been updated for Fifth Edition Specifications. *Public Works Construction Standards North Central Texas, Fifth Edition.*

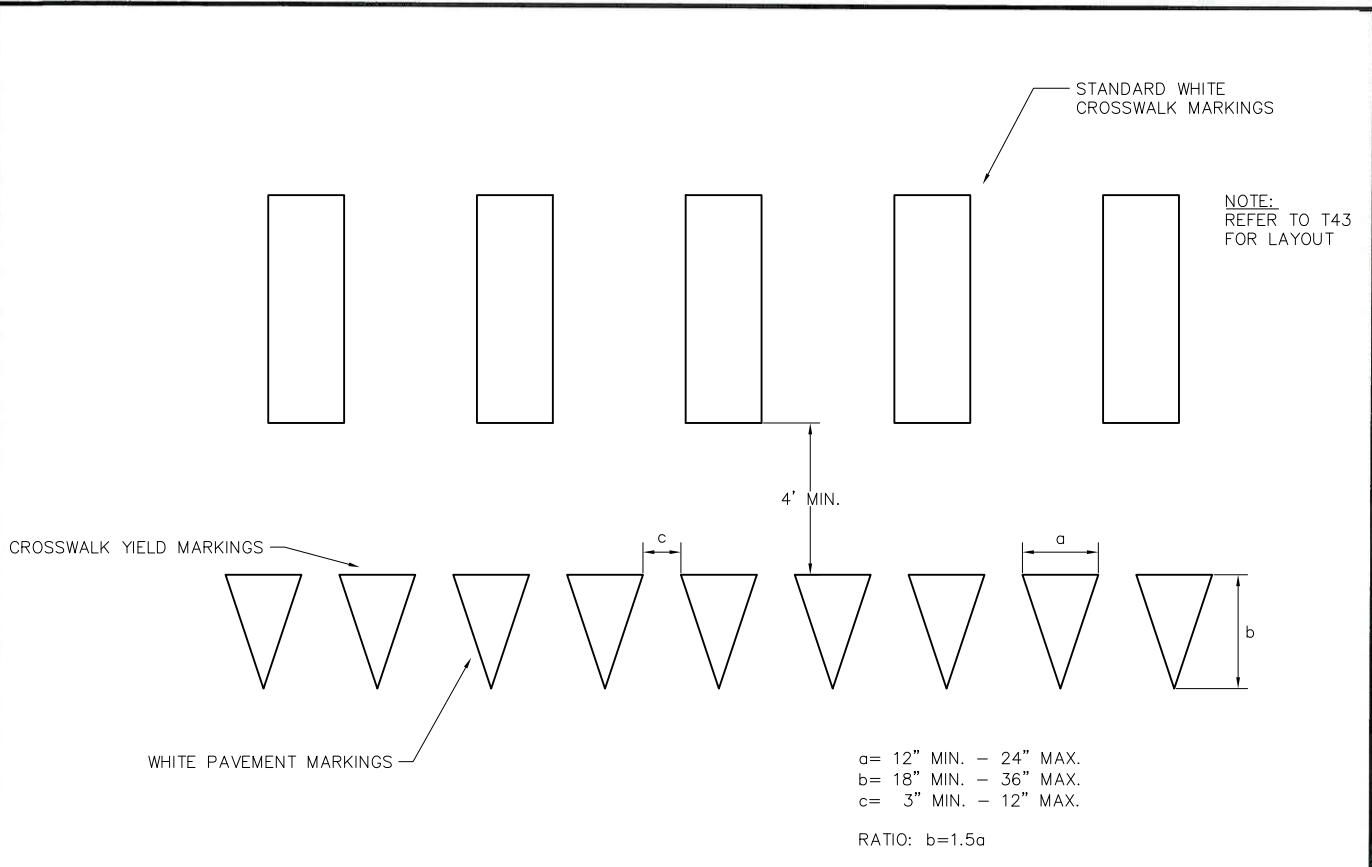

CROSSWALK MARKINGS

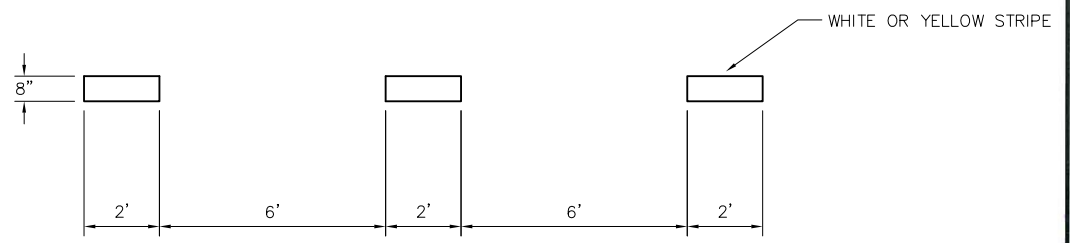

DASH LINE ("PUPPY TRACK") MARKINGS

TYPICAL CROSSWALK AND DASHED MARKINGS	CITY OF ROCKWALL 	STANDARD SPECIFICATION REFERENCE	
		DATE Mar. 2018	STANDARD DRAWING NO. R-2380

*Section II Standard Drawings as of October 2004. Reference number only has been updated for Fifth Edition Specifications. *Public Works Construction Standards North Central Texas, Fifth Edition.*

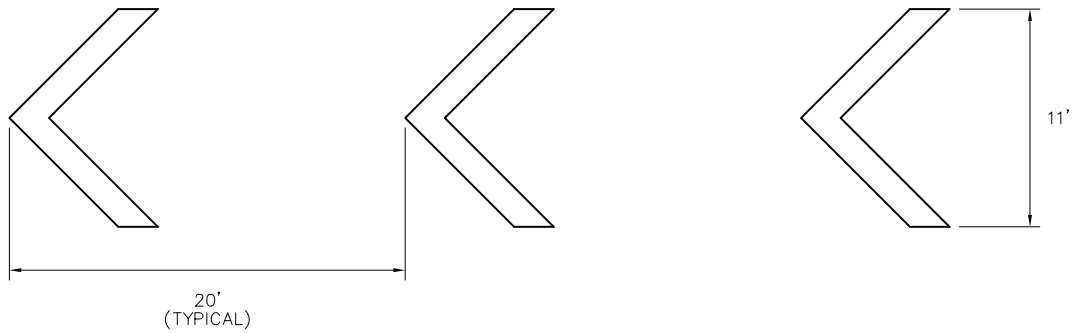

11' WIDE CHEVRON STRIPE

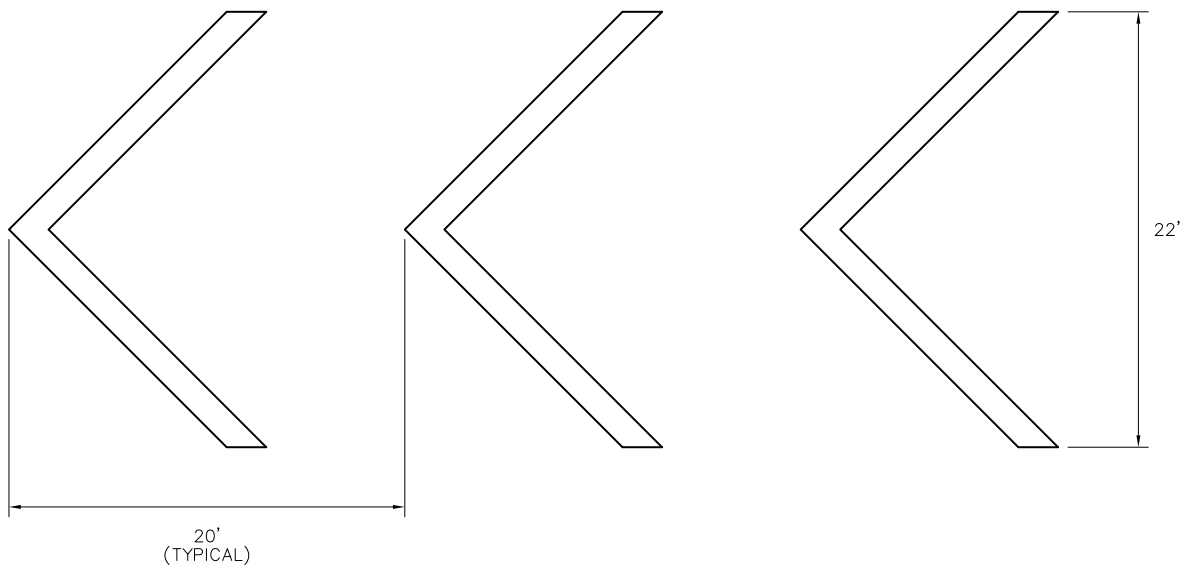

22' WIDE CHEVRON STRIPE

CHEVRON STRIPING	CITY OF ROCKWALL 	STANDARD SPECIFICATION REFERENCE	
		DATE Mar. 2018	STANDARD DRAWING NO. R-2390

*Section II Standard Drawings as of October 2004. Reference number only has been updated for Fifth Edition Specifications. *Public Works Construction Standards North Central Texas, Fifth Edition.*

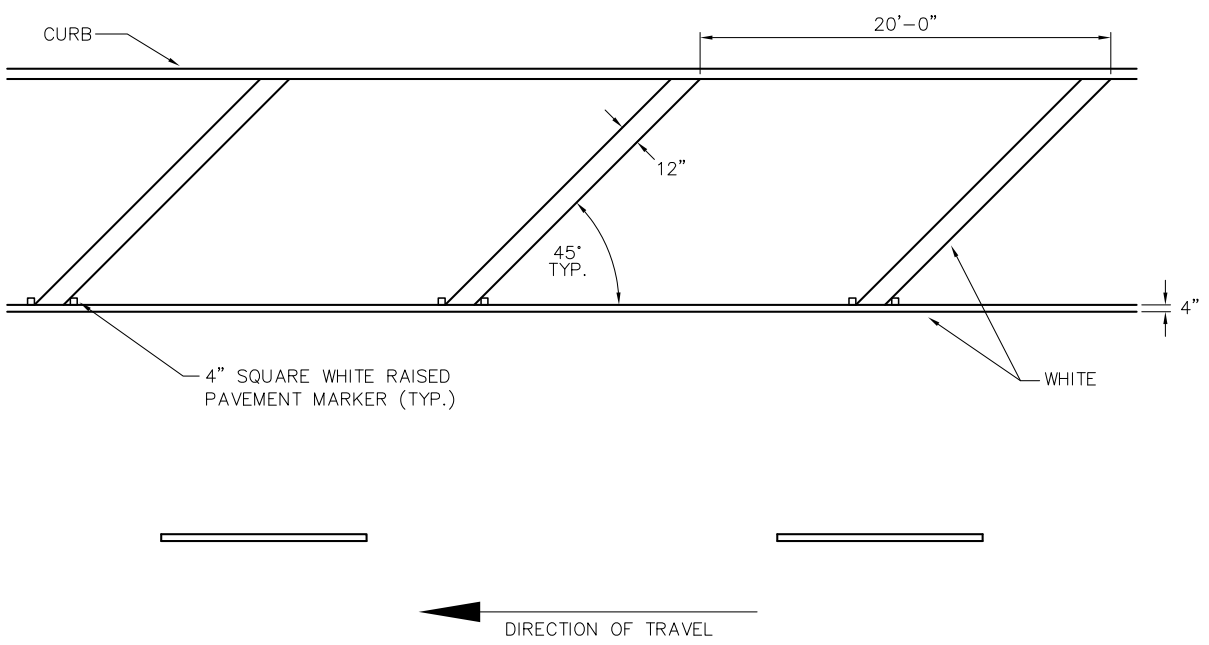
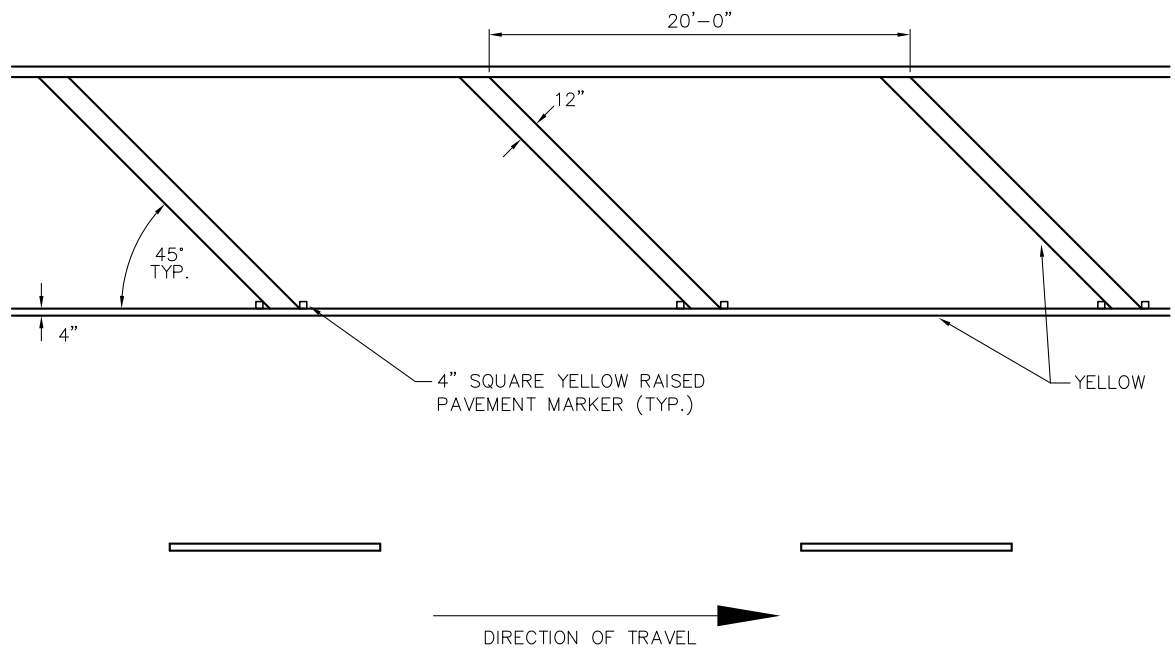

DIAGONAL CROSSHATCH	CITY OF ROCKWALL	STANDARD SPECIFICATION REFERENCE	
STRIPING		DATE Mar. 2018	STANDARD DRAWING NO. R-2400

*Section II Standard Drawings as of October 2004. Reference number only has been updated for Fifth Edition Specifications. *Public Works Construction Standards North Central Texas, Fifth Edition.*